

Report No. : SET2014-14432

RF TEST REPORT

Report No.: SET2014-14432
Product: USB Wireless Module
Model No.: GWF-3M08-3.3V/GWF-3M08-5V
Applicant: Shenzhen Ogemray Technology Co., Ltd.
Address: 3/F~4/F,NO.5 Bldg, Dongwu Industrial Park, Donghuan 1st Road, Longhua Town, Shenzhen, China
Issued by: CCIC Southern Electronic Product Testing (Shenzhen) Co., Ltd.
Lab Location: Electronic Testing Building, Shahe Road, Xili, Nanshan District, Shenzhen, 518055, P. R. China
Tel: 86 755 26627338 **Fax:** 86 755 26627238



This test report consists of 91 pages. It may be duplicated completely for legal use with the approval of the applicant. It should not be reproduced except in full, without the written approval of our laboratory. It should not be used to claim product endorsement by CCIC-SET. The test results in the report only apply to the tested sample. The test report shall be invalid without all the signatures of testing engineers, reviewer and approver. Any objections must be raised to CCIC-SET within 15 days since the date when the report is received. It will not be taken into consideration beyond this limit.



查询码: 47X170S6



Test Report

Product : USB Wireless Module

Model No. : GWF-3M08-3.3V/GWF-3M08-5V

Brand Name..... : N/A

Trade Name : N/A

Applicant : Shenzhen Ogemray Technology Co., Ltd.

Applicant Address : 3/F~4/F,NO.5 Bldg, Dongwu Industrial Park, Donghuan
1st Road, Longhua Town, Shenzhen, China

Manufacturer : Shenzhen Ogemray Technology Co., Ltd.

Manufacturer Address..... : 3/F~4/F,NO.5 Bldg, Dongwu Industrial Park, Donghuan
1st Road, Longhua Town, Shenzhen, China

Test Standards : ETSI EN 300 328 V1.8.1 (2012-06) Electromagnetic
compatibility and Radio spectrum Matters (ERM);
Wideband transmission systems; Data transmission
equipment operating in the 2,4 GHz ISM band and using
wide band modulation techniques; Harmonized EN
covering essential requirements under article 3.2 of the
R&TTE Directive

Test Result..... : Pass

Tested by : Haigang He 2014.12.22
Haigang He, Test Engineer

Reviewed by : Zhu Qi 2014.12.22
Zhu Qi, Senior Engineer

Approved by..... : Wu Lian 2014.12.22
Wu Li'an, Manager



Table of Contents

| | |
|--|------------|
| 1. GENERAL INFORMATION | 4 |
| 1.1. Description of EUT | 4 |
| 1.2. Test Standards and Results | 4 |
| 1.3. Table for Test Modes | 5 |
| 1.4. Test Equipments Utilized..... | 6 |
| 1.5. Table for Carrier Frequency | 6 |
| 1.6. Environmental Conditions | 7 |
| 1.7. Measurement Uncertainty..... | 7 |
| 1.8. System Setting | 7 |
| 1.9. Test Facility..... | 8 |
| 2. TRANSMITTER PARAMETERS | 9 |
| 2.1. EN 300 328 §4.3.2.1 - RF Output power | 9 |
| 2.2. EN 300 328 §4.3.2.2 - Power Spectral Density | 22 |
| 2.3. EN 300 328 §4.3.2.5 - Adaptivity..... | 34 |
| 2.4. EN 300 328 §4.3.2.6 - Occupied Channel Bandwidth | 51 |
| 2.5. EN 300 328 §4.3.2.7 - Transmitter unwanted emissions in the out-of-band domain | 59 |
| 2.6. EN 300 328 §4.3.2.8 - Transmitter unwanted emissions in the spurious domain..... | 69 |
| 3. RECEIVER PARAMETERS..... | 78 |
| RECEIVER SPURIOUS EMISSIONS ARE EMISSIONS AT ANY FREQUENCY WHEN THE EQUIPMENT IS IN RECEIVE MODE..... | 78 |
| ANNEX A ACCREDITATION CERTIFICATE | 86 |
| ANNEX B INFORMATION AS REQUIRED BY EN 300 328 V1.8.1 | |
| CLAUSE 5.3.1 | 87 |
| THE VALUE Q AS REFERRED TO IN CLAUSE 4.3.2.5.2.2.2: 32 | 87 |
| THE VALUE Q AS REFERRED TO IN CLAUSE 4.3.2.5.2.2.2: 32 | 88 |
| ANNEX C PHOTOS OF THE EUT | 889 |
| MODE NO.: GWF-3M08-3.3V | 889 |
| MODE NO.: GWF-3M08-5V | 90 |
| ANNEX D PHOTOS OF TEST SETUP..... | 91 |

| Change History | | |
|----------------|------------|-------------------|
| Issue | Date | Reason for change |
| 1.0 | 2014.12.22 | First edition |
| | | |
| | | |

1. General Information

1.1. Description of EUT

EUT Type: USB Wireless Module
 Adaptive Techniques: Load Based Equipment
 Hardware Version: 1.3
 Software Version: 2.0
 Modulation technology.....: DSSS, OFDM
 Modulation Type: Please see section 1.3
 Frequency Range.....: 802.11b/g/n-20:2.412GHz - 2.472GHz (at interval of 5MHz)
 802.11n-40: 2.422GHz - 2.462GHz (at interval of 5MHz)
 Antenna Gain.....: 2dBi

Note 1: The EUT is a USB Wireless Module. It contains WIFI Module operating at 2.4GHz ISM band. And the WIFI was tested in this report.

Note 2: It supports 802.11b, 802.11g and 802.11n, the 802.11b, 802.11g, 802.11n20 and 802.11n40 was tested in this report.

Note 3: Please refer to ANNEX A for the photographs of the EUT. For a more detailed description, please refer to Specification or User’s Manual supplied by the applicant and/or manufacture.

Note 4: If interference will be detected, the EUT will reduce the transmit power (<10dBm).

Note 5: The EUT is a USB Wireless Module, it contains two modes, they are GWF-3M08-3.3V and GWF-3M08-5V, and all of them have no difference but power supply.

1.2. Test Standards and Results

The EUT has been tested according to ETSI EN 300 328 V1.8.1 (2012-06).

| | |
|----------------------------------|--|
| ETSI EN 300 328 V1.8.1 (2012-06) | Electromagnetic compatibility and Radio spectrum Matters (ERM); Wideband transmission systems; Data transmission equipment operating in the 2,4 GHz ISM band and using wide band modulation techniques; Harmonized EN covering essential requirements under article 3.2 of the R&TTE Directive |
|----------------------------------|--|

Test items and the results are as bellow:

| EN Reference | | EN 300 328 V1.8.1 | Result |
|--------------|------------|---|-----------------------|
| No | Sub clause | Test Items | |
| 1 | 4.3.2.1 | RF Output Power | PASS |
| 2 | 4.3.2.2 | Power Spectral Density | PASS |
| 3 | 4.3.2.3 | Duty cycle ,Tx-sequence, Tx-gap | N/A ^{Note 1} |
| 4 | 4.3.1.3 | Dwell time, Minimum Frequency Occupation & Hopping Sequence | N/A ^{Note 2} |
| 5 | 4.3.1.4 | Hopping Frequency Separation | N/A ^{Note 2} |
| 6 | 4.3.2.4 | Medium Utilisation | N/A ^{Note 1} |

| | | | |
|----|----------|---|------------------------|
| 7 | 4.3.2.5 | Adaptivity | PASS |
| 8 | 4.3.2.6 | Occupied Channel Bandwidth | PASS |
| 9 | 4.3.2.7 | Transmitter unwanted emissions in the OOB domain | PASS |
| 10 | 4.3.2.8 | Transmitter unwanted emissions in the spurious domain | PASS |
| 11 | 4.3.2.9 | Receiver spurious emissions | PASS |
| 12 | 4.3.2.10 | Receiver Blocking | PASS ^{Note 3} |

Note 1: The EUT is an adaptive frequency hopping equipment and can't work in a non-adaptive mode.

Note 2: The EUT is using other types of wide band modulation (DSSS, OFDM).

Note 3: The conformance tests for this requirement are part of the conformance tests defined for adaptivity

1.3. Table for Test Modes

| Modulation technology | Modulation Type | Transfer Rate (Mbps) | Test Rate(Mbps) |
|-----------------------|-----------------|----------------------|-----------------|
| DSSS (802.11b) | DBPSK | 1 | 11 |
| | DQPSK | 2 | |
| | CCK | 5.5/ 11 | |
| OFDM (802.11g) | BPSK | 6 / 9 | 54 |
| | QPSK | 12 / 18 | |
| | 16QAM | 24 / 36 | |
| | 64QAM | 48 / 54 | |
| OFDM (802.11n-20MHz) | BPSK | 6.5 | 65 |
| | QPSK | 13/19.5 | |
| | 16QAM | 26/39 | |
| | 64QAM | 52/58.5/65 | |
| OFDM (802.11n-40MHz) | BPSK | 13.5 | 135 |
| | QPSK | 27/40.5 | |
| | 16QAM | 54/81/108 | |
| | 64QAM | 121.5/135 | |

Note: Preliminary tests were performed in different data rate in above table to find the worst radiated emission. The data rate shown in the table below is the worst-case rate with respect to the specific test item. Investigation has been done on all the possible configurations for searching the worst cases. The following table is a list of the test modes shown in this test report.

| Test Items | Mode | Channel | |
|--|-----------------------|---------|--------|
| RF output power | 11b / 11g/11n20/11n40 | 1/7/13 | 3/7/11 |
| Power Spectral Density | 11b / 11g/11n20/11n40 | 1/7/13 | 3/7/11 |
| Adaptivity | 11b / 11g/11n20/11n40 | 1/7/13 | 3/7/11 |
| Occupied Channel Bandwidth | 11b / 11g/11n20/11n40 | 1/7/13 | 3/7/11 |
| Transmitter unwanted emissions in the OOB domain | 11b / 11g/11n20/11n40 | 1/7/13 | 3/7/11 |

| | | | |
|---|-----------------------|--------|--------|
| Transmitter unwanted emissions in the spurious domain | 11b / 11g/11n20/11n40 | 1/7/13 | 3/7/11 |
| Receiver spurious emissions | 11b / 11g/11n20/11n40 | 1/7/13 | 3/7/11 |
| Receiver Blocking | 11b / 11g/11n20/11n40 | 1/7/13 | 3/7/11 |

1.4. Test Equipments Utilized

| TS 8997 Test System | | | | | |
|---------------------|---------------------------|------------|-----------|--------------|--------------|
| No. | Equipment Name | Serial No. | Model No. | Manufacturer | Cal.Due Date |
| 1 | Spectrum Analyzer | 101008 | FSV-40 | R&S | 2015.05.06 |
| 4 | Vector Signal Generator | 105328 | SMU200A | R&S | 2015.05.04 |
| 5 | Signal Generator | 177649 | SMB100A | R&S | 2015.04.29 |
| 6 | Switch Unit with OSP-B157 | 101130 | OSP120 | R&S | 2015.06.04 |

EMC 32 Version: 9.15.01/1.15.30

| Climate Chamber | | | | | |
|-----------------|---------------------------------------|------------|-------------|----------------------------------|---------------|
| No. | Equipment Name | Serial No. | Model No. | Manufacturer | Cal. Due Date |
| 1 | Constant Temperature humidity chamber | A130301254 | GD-7005-100 | Dongguan gaoda instrument CO.LTD | 2015.06.10 |

NOTE 1: Equipments listed above have been calibrated and are in the period of validation.

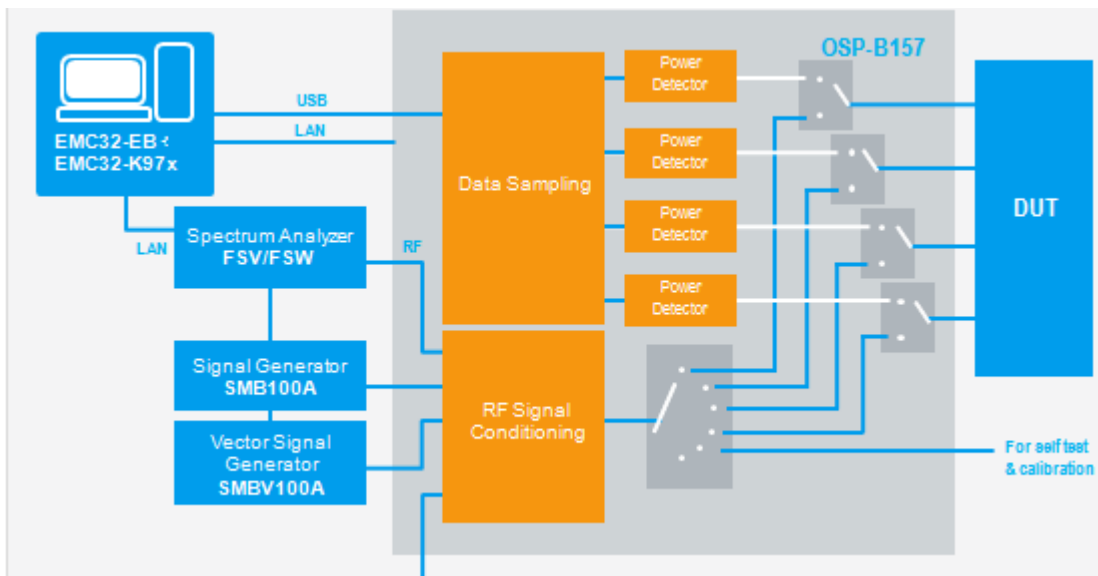

1.5. Table for Carrier Frequency

The EUT(Mode No.:GWF-3M08-3.3V) is powered by the USB which is charged with the AC Adapter (AE-1) powered by 230VAC, 50Hz AC mains supply. During the test, 3.3V, 3.45V, 3.15DC Power are chosen and supplied by DC power supply.

The EUT(Mode No.:GWF-3M08-5V) is powered by the USB which is charged with the

AC Adapter (AE-1) powered by 230VAC, 50Hz AC mains supply. During the test, 5V, 5.25V, 4.75DC Power are chosen and supplied by DC power supply.

The sample work and stay in continuous transmitting mode through its serial ports. Test frequency 2412MHz(1channel), , 2442MHz(7channel), 2472MHz(13channel) and HT40 2422MHz(3channel), 2442MHz(7channel) 2462MHz(11channel) are chosen for tested.

1.6. Environmental Conditions

Ambient temperature: 15~35 °C

Relative humidity: 30~60%

Atmosphere pressure: 86-106kPa

1.7. Measurement Uncertainty

| PARAMETER | UNCERTAINTY |
|---|-----------------------------------|
| RF Output Power | $\pm 0.08\text{dB}$ |
| Power Spectral Density | $\pm 0.08\text{dB}$ |
| Occupied Channel Bandwidth | $\pm 0.0019\text{Hz}$ |
| Transmitter unwanted emissions in the OOB domain | $\pm 2.7\text{dB}$ |
| Transmitter unwanted emissions in the spurious domain | $\pm 2.7\text{dB}$ |
| Receiver spurious emissions | $\pm 2.7\text{dB}$ |
| Adaptivity | $\pm 3.05\text{dB}$ |
| Humidity | $\pm 3.1\%$ |
| Temperature | $\pm 0.8\text{ }^{\circ}\text{C}$ |
| DC and low frequency voltages | $\pm 2.9\%$ |

For the test methods, according to the present document, the measurement uncertainty figures shall be calculated in according with TR 100 028-1[2] and shall correspond to an expansion to expansion factor (coverage factor) $k=1.96$ or $k=2$ (which provide confidence levels of respectively 95% and 95.45% in the case where the distributions characterizing the actual measurement uncertainties are normal (Gaussian)).

1.8. System Setting

| Setting | Value |
|-------------------------------|-------|
| Modulation | other |
| Adaptive | Yes |
| Number Of Transmission Chains | 1 |
| Antenna Gain Port 1 | 2dBi |
| Beamforming Gain | 0 dB |



| | |
|--|----------------------------|
| Nominal Channel Bandwidth | 20 MHz/40MHz |
| Maximum EIRP | 20 dBm |
| Attenuation / Pathloss File Port 1 | DUT cable 12.75Ghz_10dB |
| Sourious Tx Receiver reference level below | 20 dB |
| power measurement for radiated | No |
| DUT Port Occupied Channel Bandwidth | 1 |
| LBT Based | Yes |
| Dual Mode | No |
| Short Signaling | Yes |
| Frame Based | No |
| Load Based | Yes |
| Adaptivity q Factor | 32 |
| CCA | 20 us |
| DUT Port Adaptivity | 1 |
| Channel Occupation Time | 15 ms |

1.9. Test Facility

CCIC Southern Electronic Product Testing (Shenzhen) Co., Ltd. CCIC is a third party testing organization accredited by China National Accreditation Service for Conformity Assessment (CNAS) according to ISO/IEC 17025. The accreditation certificate number is L1659.

2. Transmitter Parameters

2.1. EN 300 328 §4.3.2.1 - RF Output power

The RF output power is defined as the mean equivalent isotropic radiated power (e.i.r.p.) of the equipment during a transmission burst.

2.1.1. Limits:

For adaptive equipment using wide band modulations other than FHSS, the maximum RF output power shall be 20 dBm.

2.1.2. Test Configuration

Please refer to 1.4

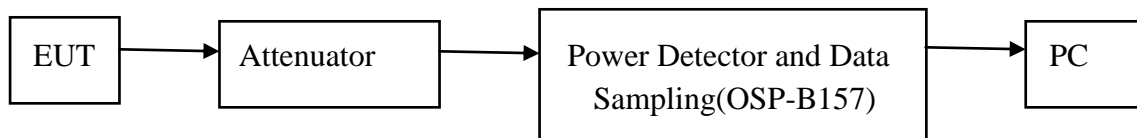

2.1.3. Test Procedure

Please refer to ETSI EN 300 328 (V1.8.1) Sub-clause 5.3.2.2 for the measurement method.

The conducted measurement method was used in this report.

These measurements shall be performed at normal and extreme test conditions.

For systems using FHSS modulation, the measurements shall be performed during normal operation (hopping).

The test procedure shall be as follows:

Step 1:

- Use a fast power sensor suitable for 2,4 GHz and capable of 1 MS/s.
- Use the following settings:
 - Sample speed 1 MS/s or faster.
 - The samples must represent the power of the signal.
 - Measurement duration: For non-adaptive equipment: equal to the observation period defined in clauses 4.3.1.2.1 or 4.3.2.3.1. For adaptive equipment, the measurement duration shall be long enough to ensure a minimum number of bursts (at least 10) are captured.

NOTE 1: For adaptive equipment, to increase the measurement accuracy, a higher number of bursts may be used.

Step 2:

- For conducted measurements on devices with one transmit chain:
 - Connect the power sensor to the transmit port, sample the transmit signal and store the raw data. Use these stored samples in all following steps.
- For conducted measurements on devices with multiple transmit chains:
 - Connect one power sensor to each transmit port for a synchronous measurement on all transmit ports.
 - Trigger the power sensors so that they start sampling at the same time. Make sure the time

difference between the samples of all sensors is less than half the time between two samples.

- For each instant in time, sum the power of the individual samples of all ports and store them.

Use these stored samples in all following steps.

Step 3:

- Find the start and stop times of each burst in the stored measurement samples.

NOTE 2: The start and stop times are defined as the points where the power is at least 20 dB below the RMS burst power calculated in step 4.

Step 4:

• Between the start and stop times of each individual burst calculate the RMS power over the burst. Save these Pburst values, as well as the start and stop times for each burst.

Step 5:

- The highest of all Pburst values (value "A" in dBm) will be used for maximum e.i.r.p. calculations.

Step 6:

- Add the (stated) antenna assembly gain "G" in dBi of the individual antenna.
- If applicable, add the additional beamforming gain "Y" in dB.
- If more than one antenna assembly is intended for this power setting, the maximum overall antenna gain (G or G + Y) shall be used.

- The RF Output Power (P) shall be calculated using the formula below:

$$P = A + G + Y$$

A: Max Burst RMS Power;

G: Antenna assembly gain;

Y: Additional beamforming gain (if applicable).

2.1.4. Result

| | |
|---|------------------------------|
| A(Conducted output power) | Refer to the following table |
| G(Antenna assembly gain) | 2dBi |
| Y {Additional beamforming gain (if applicable)} | N/A |
| EIRP | A+G |
| Limit | 20dBm |
| Mode No. | GWF-3M08-3.3V |

2.1.4.1 802.11 b Mode

| Test Conditions | | Transmitter Power Level (dBm) | | | | | |
|-----------------|-------|-------------------------------|------|-----------------------------|------|------------------------------|------|
| | | Lowest Frequency 2412MHz | | Middle Frequency 2442MHz | | Highest Frequency 2472MHz | |
| | | A | EIRP | A | EIRP | A | EIRP |
| 20 °C | 3.3V | 15.5 | 17.5 | 15.7 | 17.7 | 15.4 | 17.4 |
| -20 °C | 3.45V | 15.3 | 17.3 | 15.6 | 17.6 | 15.1 | 17.1 |
| | 3.15V | 15.2 | 17.2 | 15.4 | 17.4 | 15.3 | 17.3 |
| 55 °C | 3.45V | 15.4 | 17.4 | 15.5 | 17.5 | 15.3 | 17.3 |
| | 3.15V | 15.2 | 17.2 | 15.6 | 17.6 | 15.2 | 17.2 |
| Test Verdict | | PASS | | | | | |

801.11b mode L channel the worst test result

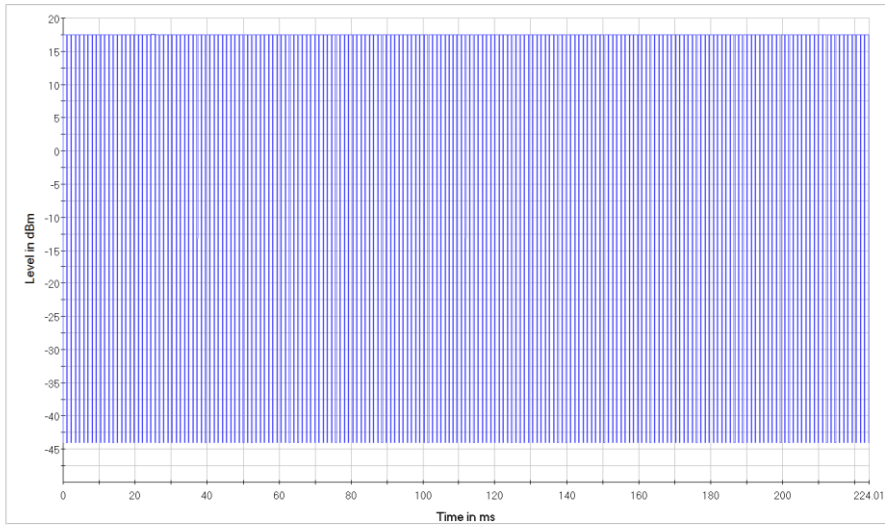

801.11b mode M channel the worst test result

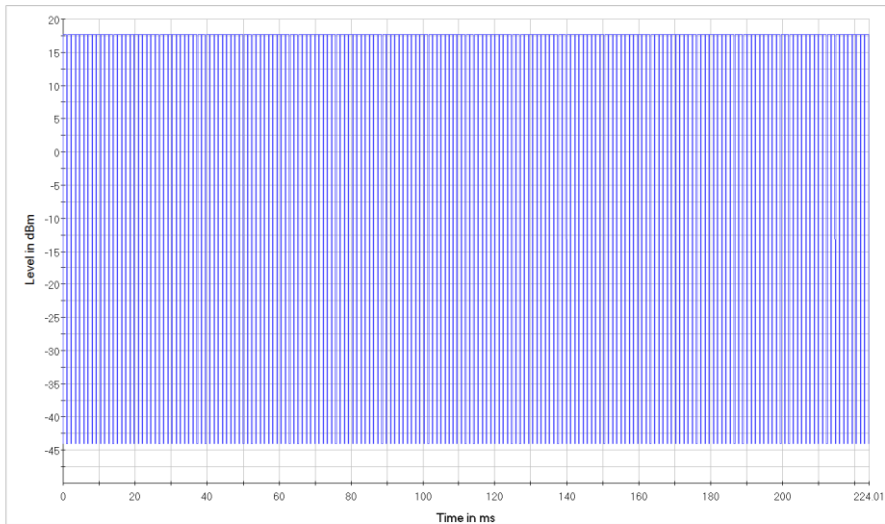

801.11b mode H channel the worst test result

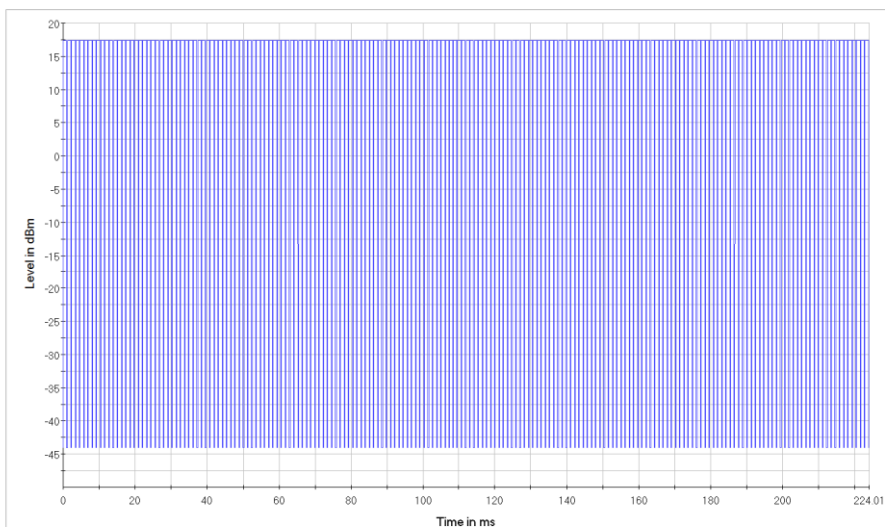

2.1.4.2 802.11 g Mode

| Test Conditions | | Transmitter Power Level (dBm) | | | | | |
|-----------------|-------|-------------------------------|------|---------------------------|------|----------------------------|------|
| | | Lowest Frequency, 2412MHz | | Middle Frequency, 2442MHz | | Highest Frequency, 2472MHz | |
| | | A | EIRP | A | EIRP | A | EIRP |
| 20 °C | 3.3V | 11.8 | 13.8 | 11.9 | 13.9 | 11.4 | 13.4 |
| -20 °C | 3.45V | 11.5 | 13.5 | 11.5 | 13.5 | 11.0 | 13.0 |
| | 3.15V | 11.6 | 13.6 | 11.4 | 13.4 | 11.3 | 13.3 |
| 55 °C | 3.45V | 11.7 | 13.7 | 11.8 | 13.8 | 11.1 | 13.1 |
| | 3.15V | 11.5 | 13.5 | 11.6 | 13.6 | 11.2 | 13.2 |
| Test Verdict | | PASS | | | | | |

801.11g mode L channel the worst test result

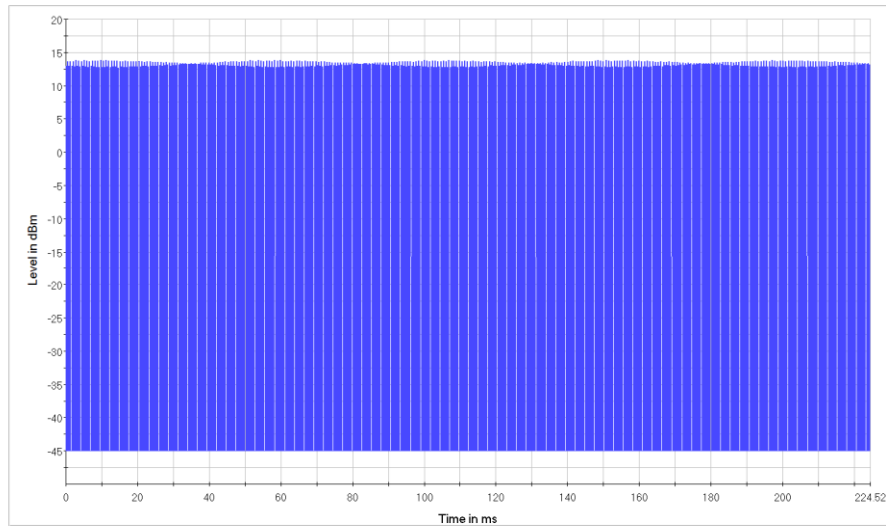

801.11g mode M channel the worst test result

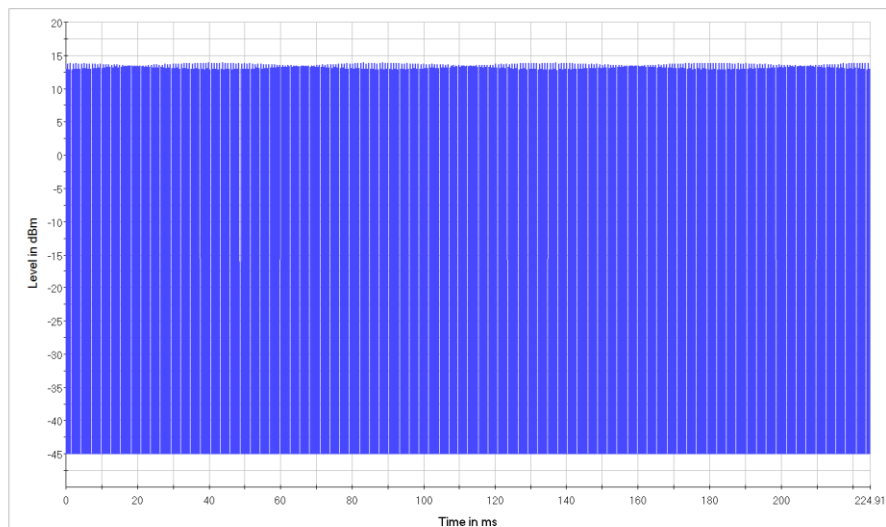

801.11g mode H channel the worst test result

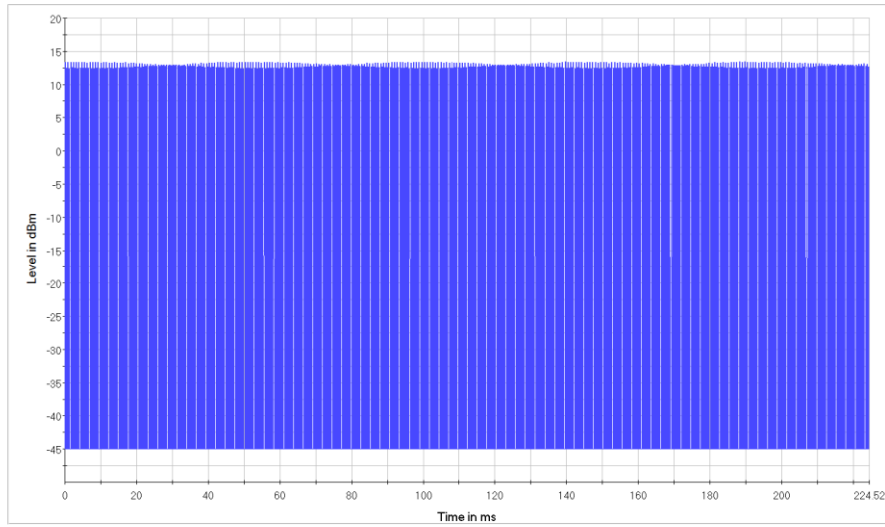

2.1.4.3 802.11n20 Mode

| Test Conditions | | Transmitter Power Level (dBm) | | | | | |
|-----------------|-------|-------------------------------|------|---------------------------|------|----------------------------|------|
| | | Lowest Frequency, 2412MHz | | Middle Frequency, 2442MHz | | Highest Frequency, 2472MHz | |
| | | A | EIRP | A | EIRP | A | EIRP |
| 20 °C | 3.3V | 10.4 | 12.4 | 10.6 | 12.6 | 10.0 | 12.0 |
| -20 °C | 3.45V | 10.2 | 12.2 | 10.5 | 12.5 | 9.7 | 11.7 |
| | 3.15V | 10.3 | 12.3 | 10.3 | 12.3 | 9.8 | 11.8 |
| 55 °C | 3.45V | 10.1 | 12.1 | 10.5 | 12.5 | 9.9 | 11.9 |
| | 3.15V | 10.2 | 12.2 | 10.4 | 12.4 | 9.6 | 11.6 |
| Test Verdict | | PASS | | | | | |

801.11n20 mode L channel the worst test result

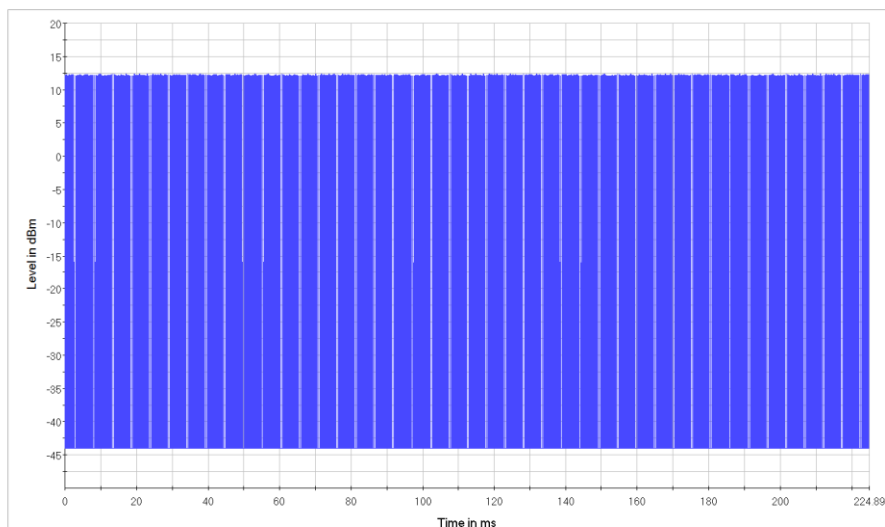

801.11n20 mode M channel the worst test result

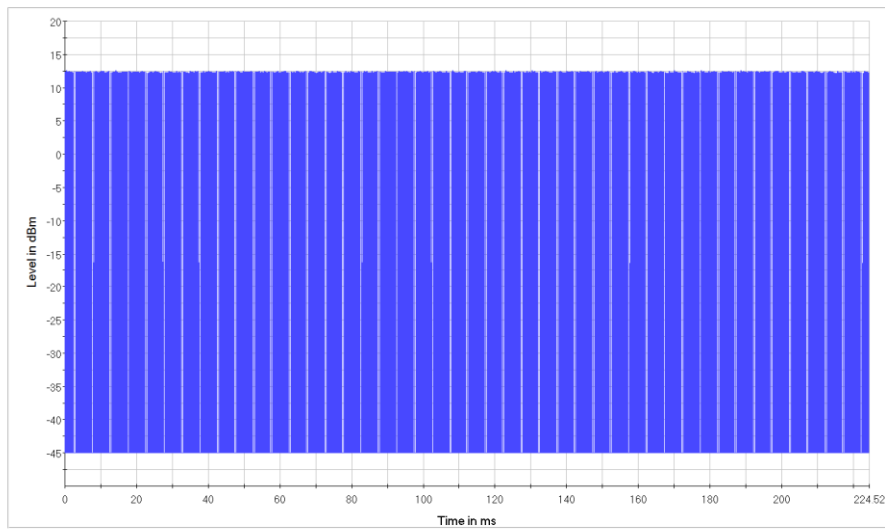

801.11n20 mode H channel the worst test result

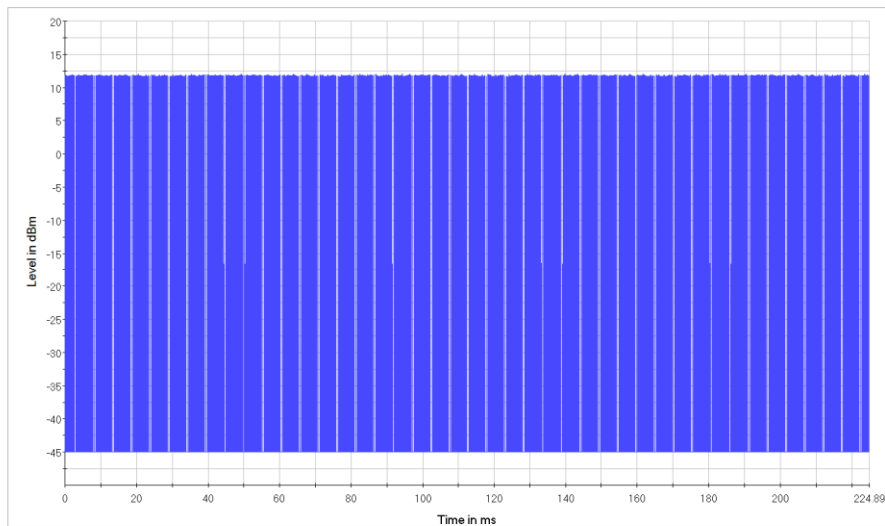

2.1.4.4 802.11 n40 Mode

| Test Conditions | | Transmitter Power Level (dBm) | | | | | |
|-----------------|-------|-------------------------------|------|---------------------------|------|----------------------------|------|
| | | Lowest Frequency, 2422MHz | | Middle Frequency, 2442MHz | | Highest Frequency, 2462MHz | |
| | | A | EIRP | A | EIRP | A | EIRP |
| 20 °C | 3.3V | 9.5 | 11.5 | 9.2 | 11.2 | 9.1 | 11.1 |
| -20 °C | 3.45V | 9.2 | 11.2 | 9.1 | 11.1 | 8.9 | 10.9 |
| | 3.15V | 9.3 | 11.3 | 9.0 | 11.0 | 8.8 | 10.8 |
| 55 °C | 3.45V | 9.4 | 11.4 | 8.9 | 10.9 | 9.0 | 11.0 |
| | 3.15V | 9.1 | 11.1 | 9.0 | 11.0 | 8.9 | 10.9 |
| Test Verdict | | PASS | | | | | |

801.11n40 mode L channel the worst test result

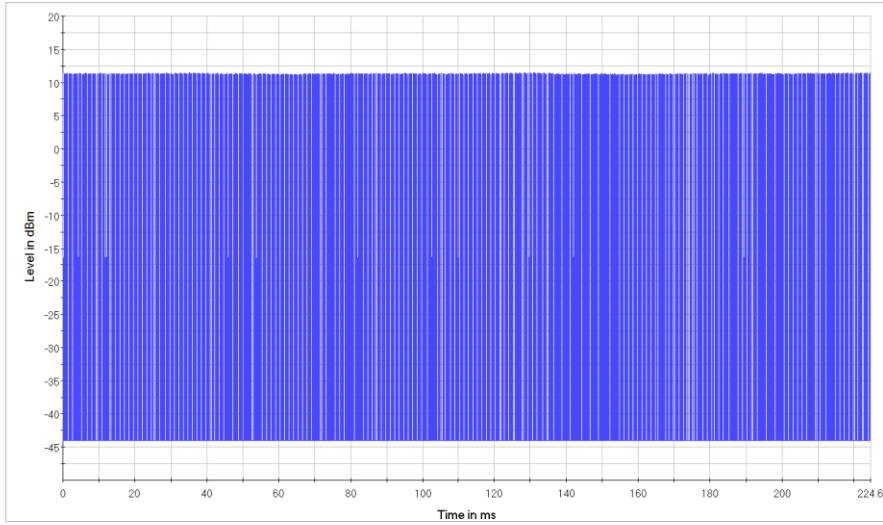

801.11n40 mode M channel the worst test result

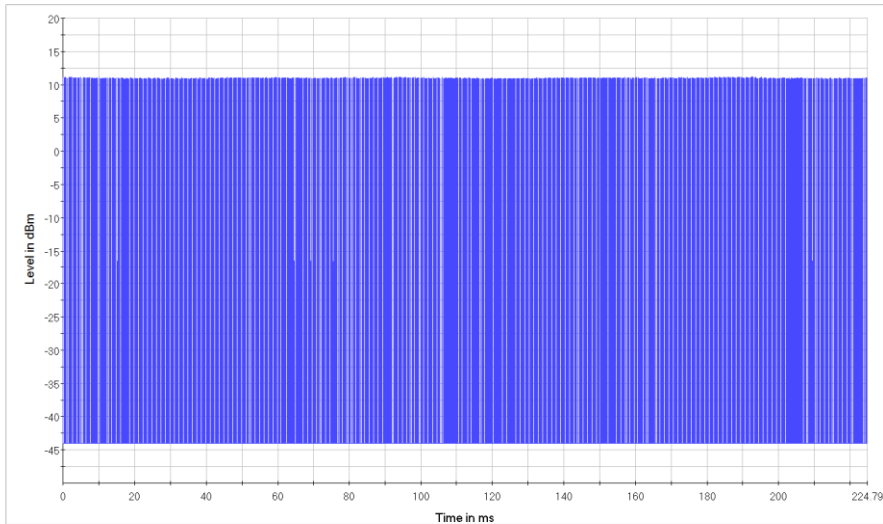

801.11n40 mode H channel the worst test result

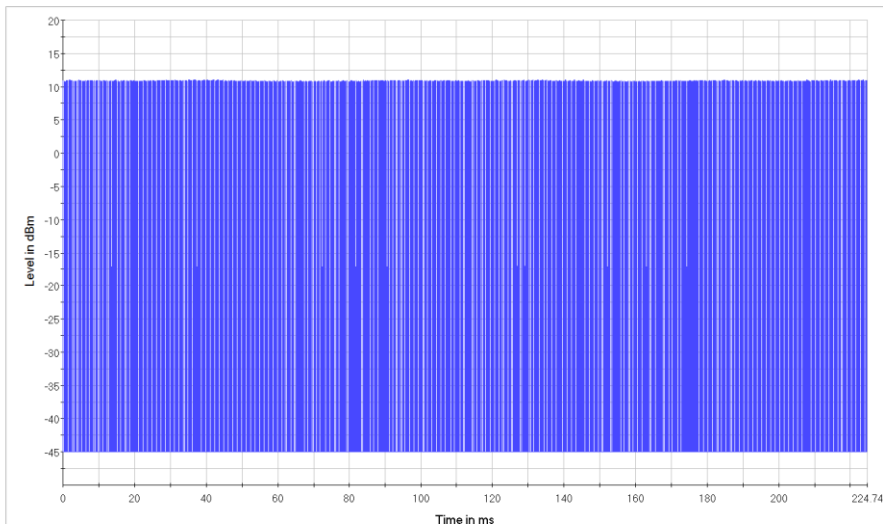



| | |
|---|------------------------------|
| A(Conducted output power) | Refer to the following table |
| G(Antenna assembly gain) | 2dBi |
| Y {Additional beamforming gain (if applicable)} | N/A |
| EIRP | A+G |
| Limit | 20dBm |
| Mode No. | GWF-3M08-5V |

2.1.4.5 802.11 b Mode

| Test Conditions | | Transmitter Power Level (dBm) | | | | | |
|-----------------|-------|-------------------------------|------|-----------------------------|------|------------------------------|------|
| | | Lowest Frequency 2412MHz | | Middle Frequency 2442MHz | | Highest Frequency 2472MHz | |
| | | A | EIRP | A | EIRP | A | EIRP |
| 20 °C | 5V | 15.6 | 17.6 | 15.4 | 17.4 | 15.5 | 17.5 |
| -20 °C | 5.25V | 15.3 | 17.3 | 15.2 | 17.2 | 15.2 | 17.2 |
| | 4.75V | 15.4 | 17.4 | 15.4 | 17.4 | 15.0 | 17.0 |
| 55 °C | 5.25V | 15.5 | 17.5 | 15.1 | 17.1 | 15.4 | 17.4 |
| | 4.75V | 15.3 | 17.3 | 15.2 | 17.2 | 15.3 | 17.3 |
| Test Verdict | | PASS | | | | | |

801.11b mode L channel the worst test result

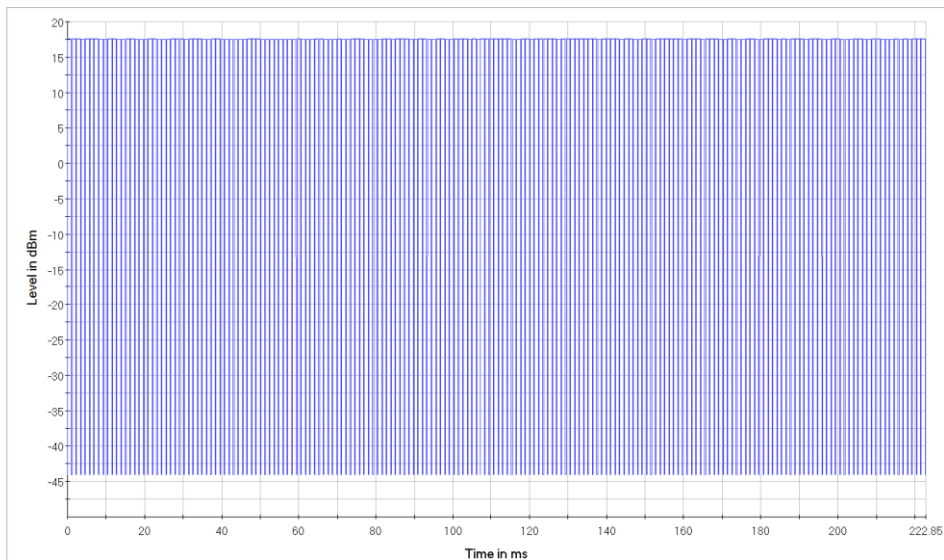

801.11b mode M channel the worst test result

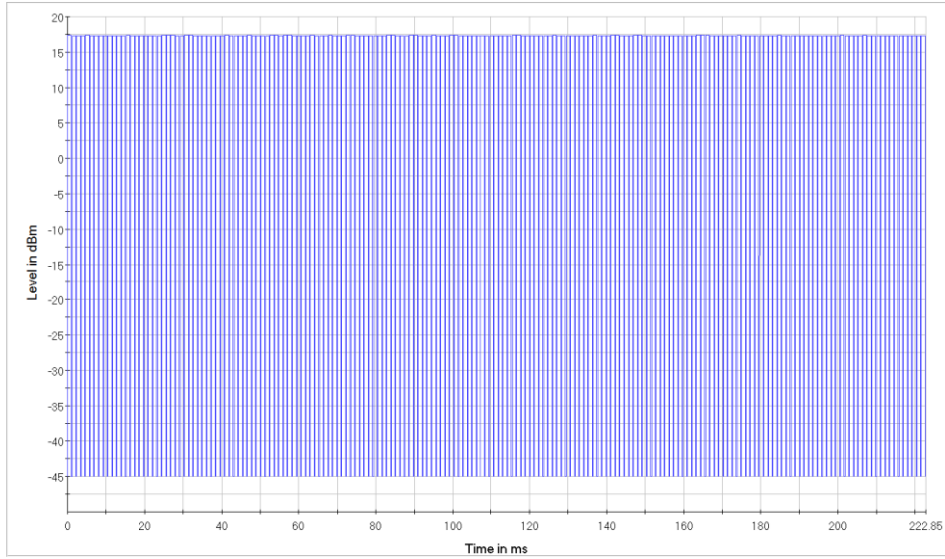

801.11b mode H channel the worst test result

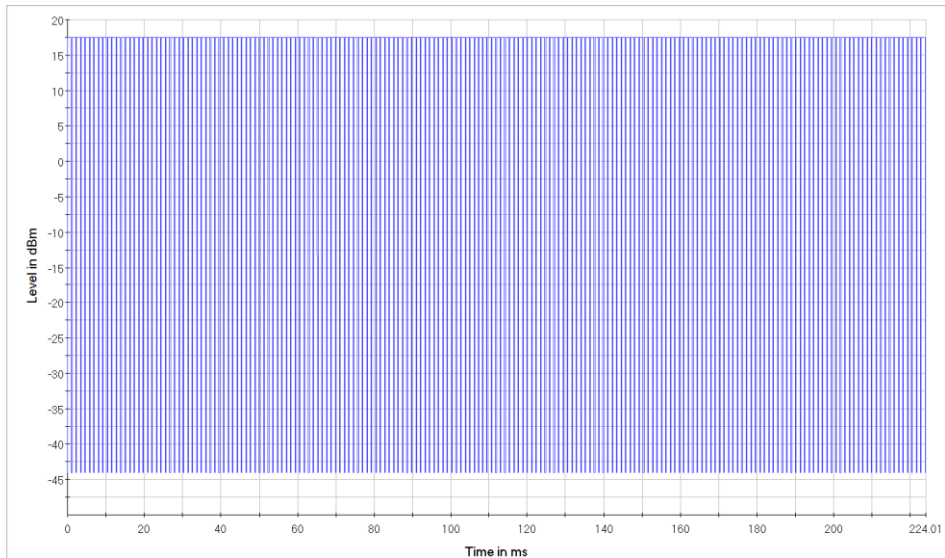

2.1.4.6 802.11 g Mode

| Test Conditions | | Transmitter Power Level (dBm) | | | | | |
|-----------------|-------|-------------------------------|------|---------------------------|------|----------------------------|------|
| | | Lowest Frequency, 2412MHz | | Middle Frequency, 2442MHz | | Highest Frequency, 2472MHz | |
| | | A | EIRP | A | EIRP | A | EIRP |
| 20 °C | 5V | 11.7 | 13.7 | 11.9 | 13.9 | 11.8 | 13.8 |
| -20 °C | 5.25V | 11.4 | 13.4 | 11.7 | 13.7 | 11.5 | 13.5 |
| | 4.75V | 11.6 | 13.6 | 11.8 | 13.8 | 11.8 | 13.8 |
| 55 °C | 5.25V | 11.3 | 13.3 | 11.5 | 13.5 | 11.6 | 13.6 |
| | 4.75V | 11.5 | 13.5 | 11.7 | 13.7 | 11.7 | 13.7 |
| Test Verdict | | PASS | | | | | |

801.11g mode L channel the worst test result

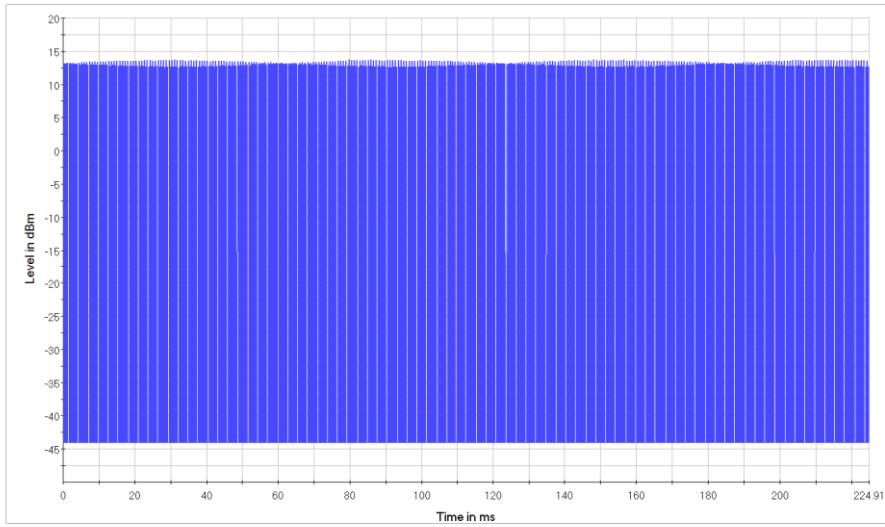

801.11g mode M channel the worst test result

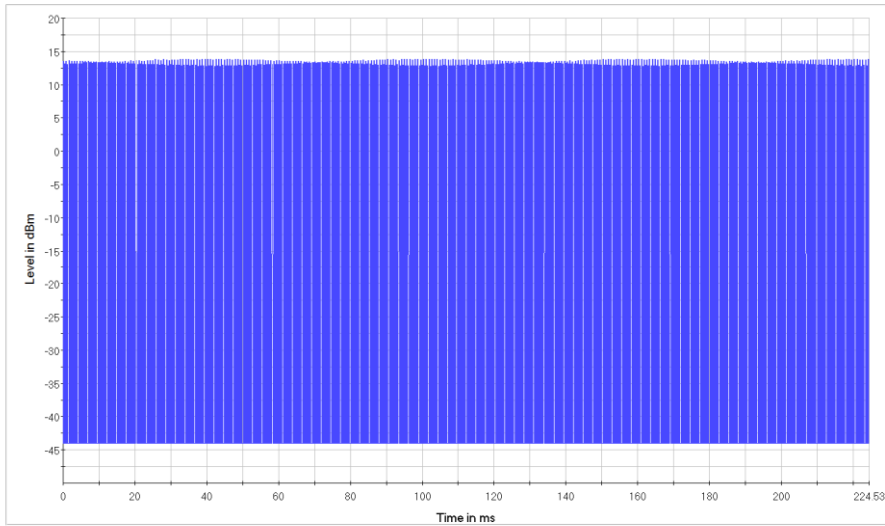

801.11g mode H channel the worst test result

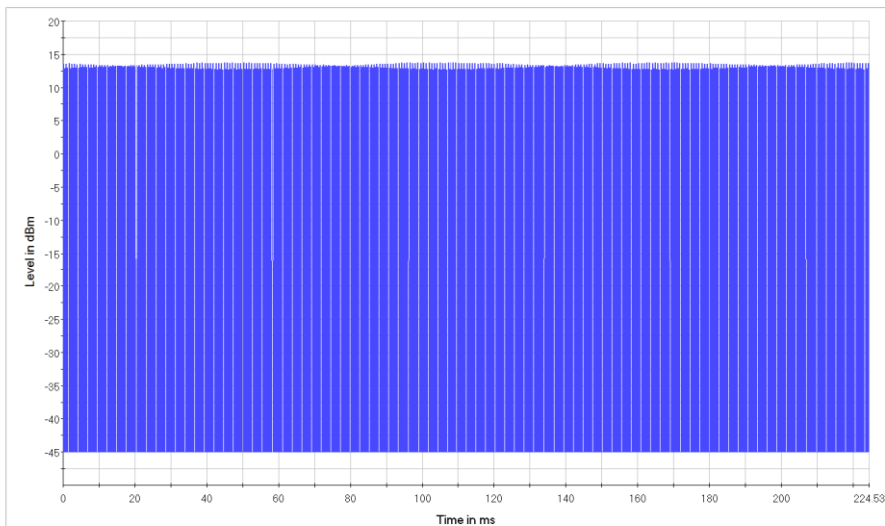

2.1.4.7 802.11n20 Mode

| Test Conditions | | Transmitter Power Level (dBm) | | | | | |
|-----------------|-------|-------------------------------|------|---------------------------|------|----------------------------|------|
| | | Lowest Frequency, 2412MHz | | Middle Frequency, 2442MHz | | Highest Frequency, 2472MHz | |
| | | A | EIRP | A | EIRP | A | EIRP |
| 20 °C | 5V | 9.9 | 11.9 | 10.0 | 12.0 | 10.4 | 12.4 |
| -20 °C | 5.25V | 9.8 | 11.8 | 9.7 | 11.7 | 10.0 | 12.0 |
| | 4.75V | 9.5 | 11.5 | 9.9 | 11.9 | 10.3 | 12.3 |
| 55 °C | 5.25V | 9.7 | 11.7 | 9.6 | 11.6 | 10.1 | 12.1 |
| | 4.75V | 9.8 | 11.8 | 9.8 | 11.8 | 10.2 | 12.2 |
| Test Verdict | | PASS | | | | | |

801.11n20 mode L channel the worst test result

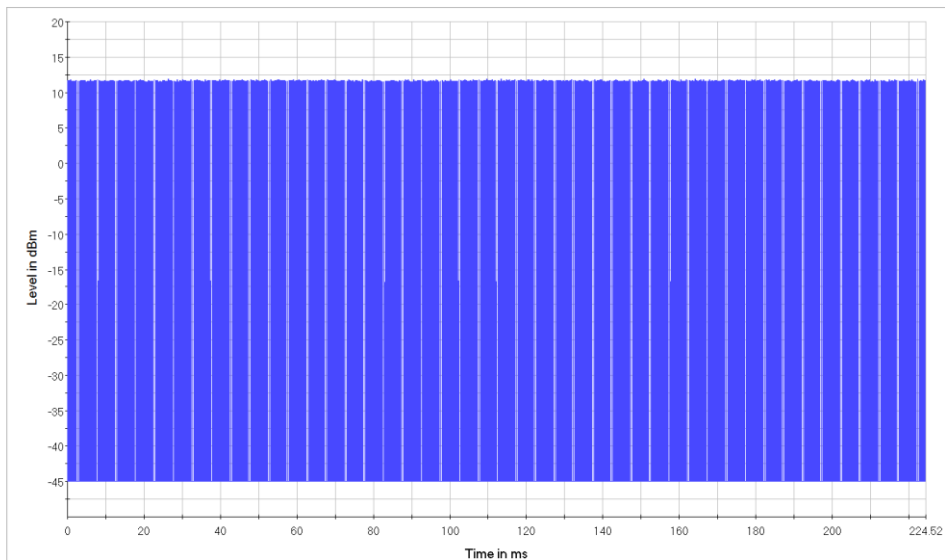

801.11n20 mode M channel the worst test result

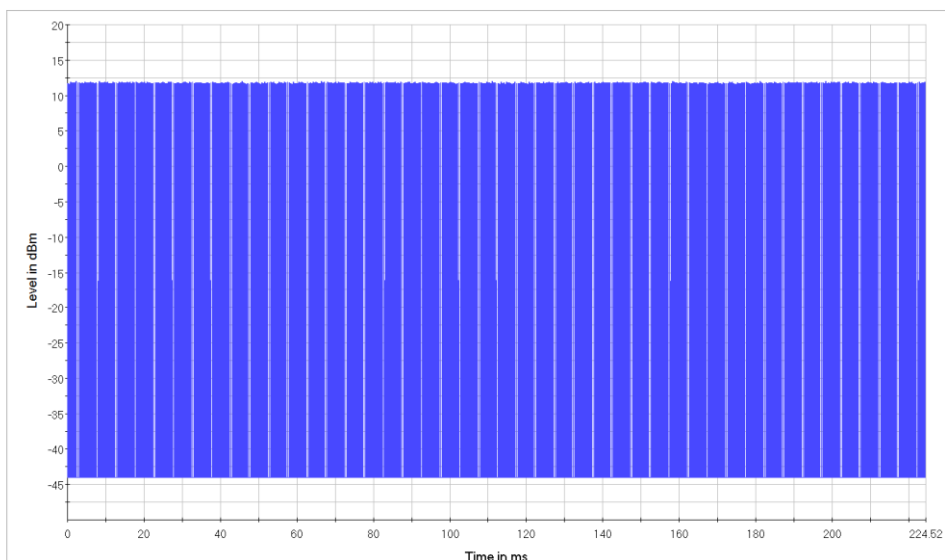

801.11n20 mode H channel the worst test result

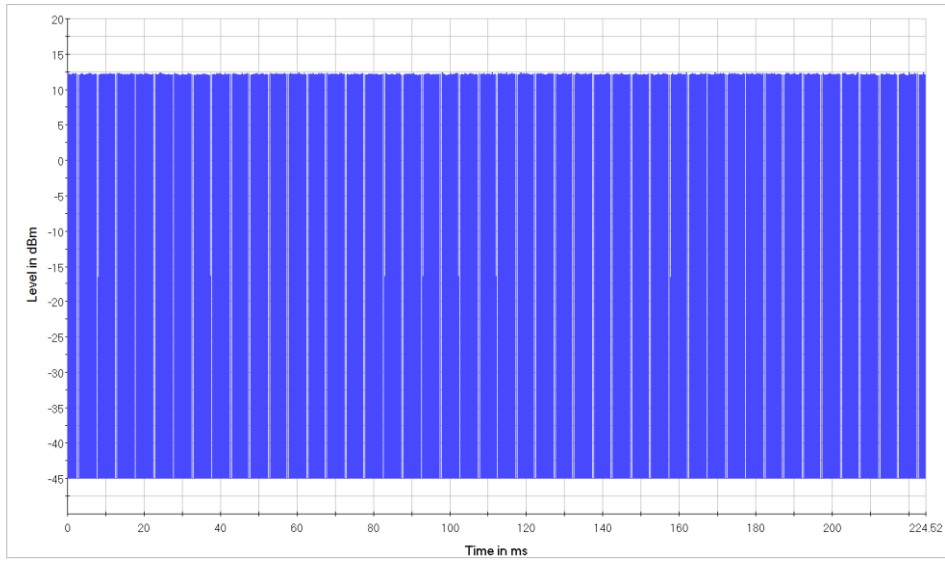

2.1.4.8 802.11 n40 Mode

| Test Conditions | | Transmitter Power Level (dBm) | | | | | |
|-----------------|-------|-------------------------------|------|---------------------------|------|----------------------------|------|
| | | Lowest Frequency, 2422MHz | | Middle Frequency, 2442MHz | | Highest Frequency, 2462MHz | |
| | | A | EIRP | A | EIRP | A | EIRP |
| 20 °C | 5V | 9.6 | 11.6 | 9.6 | 11.6 | 9.5 | 11.5 |
| -20 °C | 5.25V | 9.2 | 11.2 | 9.5 | 11.5 | 9.2 | 11.2 |
| | 4.75V | 9.5 | 11.5 | 9.2 | 11.2 | 9.4 | 11.4 |
| 55 °C | 5.25V | 9.4 | 11.4 | 9.4 | 11.4 | 9.1 | 11.1 |
| | 4.75V | 9.3 | 11.3 | 9.3 | 11.3 | 9.2 | 11.2 |
| Test Verdict | | PASS | | | | | |

801.11n40 mode L channel the worst test result

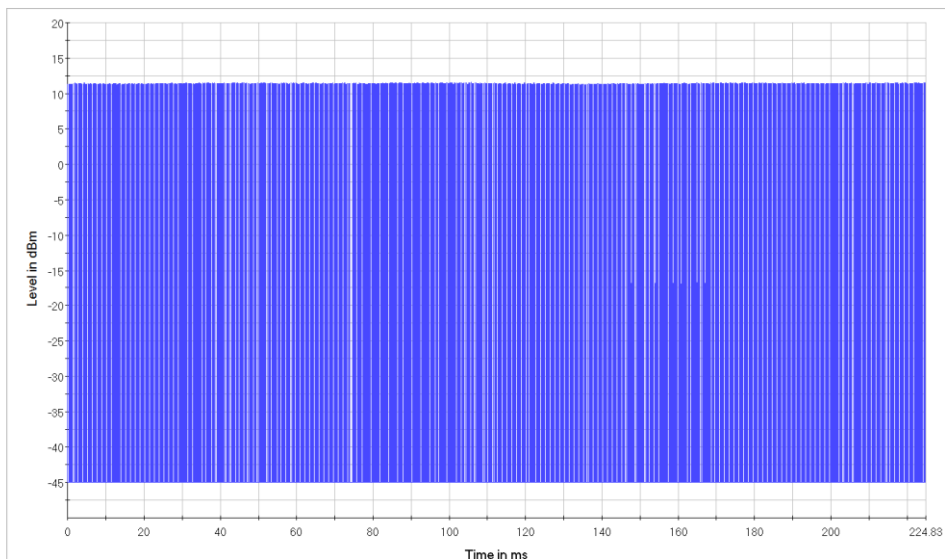

801.11n40 mode M channel the worst test result

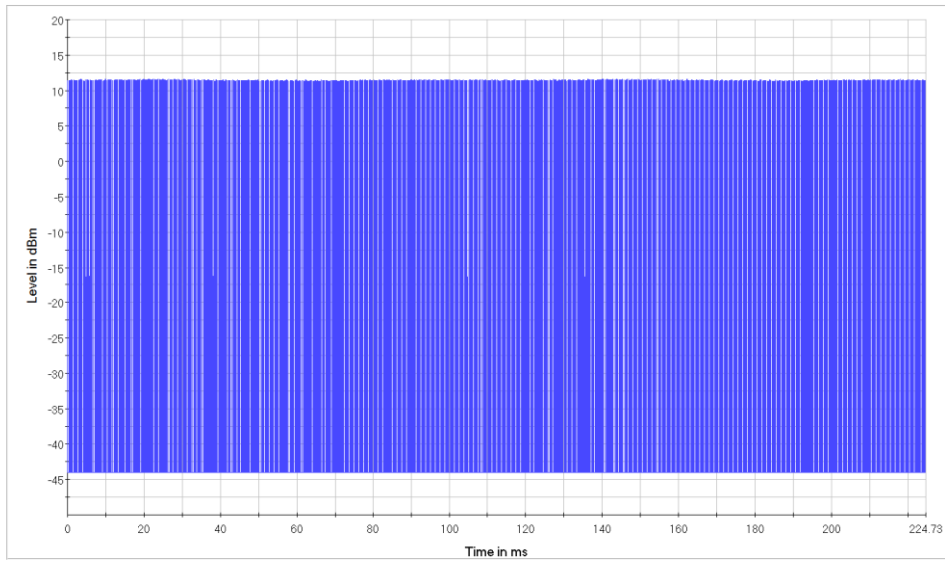

801.11n40 mode H channel the worst test result

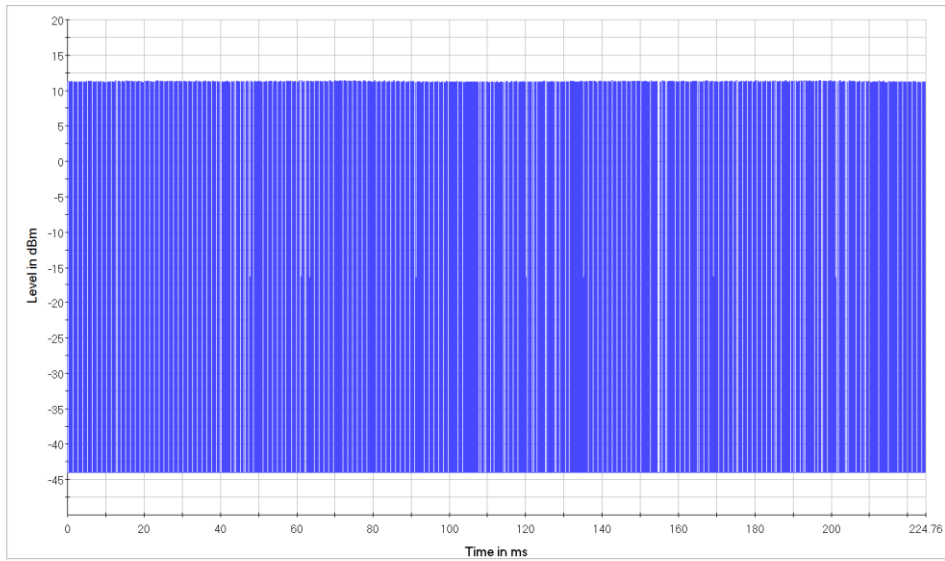

2.2. EN 300 328 §4.3.2.2 - Power Spectral Density

The Power Spectral Density is the mean equivalent isotropically radiated power (e.i.r.p.) spectral density during a transmission burst.

2.2.1. Limit

For equipment using wide band modulations other than FHSS, the maximum Power Spectral Density is limited to 10 dBm per MHz.

2.2.2. Test Configuration

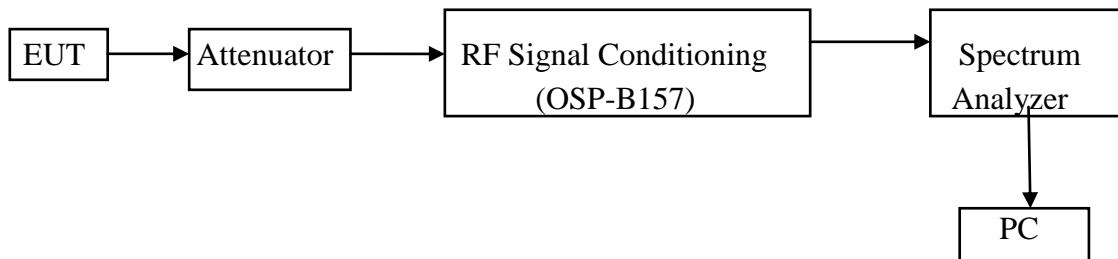

2.2.3. Test Procedure

Please refer to ETSI EN 300 328 (V1.8.1) Sub-clause 5.3.3.2 for the measurement method. The conducted measurement method was used in this report.

The measurement shall be repeated for the equipment being configured to operate at the lowest, the middle, and the highest frequency of the stated frequency range. These frequencies shall be recorded.

The test procedure shall be as follows:

Step 1:

Connect the UUT to the spectrum analyser and use the following settings:

- Start Frequency: 2 400 MHz
- Stop Frequency: 2 483,5 MHz
- Resolution BW: 10 kHz
- Video BW: 30 kHz
- Sweep Points: > 8 350

NOTE: For spectrum analysers not supporting this number of sweep points, the frequency band may be segmented.

- Detector: RMS
- Trace Mode: Max Hold
- Sweep time: Auto

For non-continuous signals, wait for the trace to be completed. Save the (trace) data set to a file.

Step 2:

For conducted measurements on smart antenna systems using either operating mode 2 or 3 (see clause 5.1.3.2), repeat the measurement for each of the transmit ports. For each frequency point, add up the amplitude (power) values for the different transmit chains and use this as the new data set.

Step 3:

Add up the values for amplitude (power) for all the samples in the file.

Step 4:

Normalize the individual values for amplitude so that the sum is equal to the RF Output

Power (e.i.r.p.) measured in clause 5.3.2.

Step 5:

Starting from the first sample in the file (lowest frequency), add up the power of the following samples representing a 1 MHz segment and record the results for power and position (i.e. sample #1 to #100). This is the Power Spectral Density (e.i.r.p.) for the first 1 MHz segment which shall be recorded.

Step 6:

Shift the start point of the samples added up in step 5 by 1 sample and repeat the procedure in step 5 (i.e. sample #2 to #101).

Step 7:

Repeat step 6 until the end of the data set and record the radiated Power Spectral Density values for each of the 1 MHz segments.

From all the recorded results, the highest value is the maximum Power Spectral Density for the UUT. This value, which shall comply with the limit given in clause 4.3.2.2.2, shall be recorded in the test report.

2.2.4. Result

| | |
|--------------|---------------|
| Temperature: | 20°C |
| Voltage: | 3.3V |
| Mode No.: | GWF-3M08-3.3V |

2.2.4.1 802.11 b Mode

| Test Condition | Temperature:20°C , Voltage:3.3V | | | | |
|----------------|---------------------------------|-----------------------------------|-------------|---------------|------------|
| Channel | Frequency (MHz) | Center Frequency of Segment (MHz) | Level (dBm) | Refer to Plot | Limit(dBm) |
| 1 | 2412 | 2414.546609 | 8.1 | Plot A | <= 10 |
| 7 | 2442 | 2441.515013 | 8.5 | Plot B | |
| 13 | 2472 | 2472.483181 | 8.3 | Plot C | |
| Test Verdict | | PASS | | | |

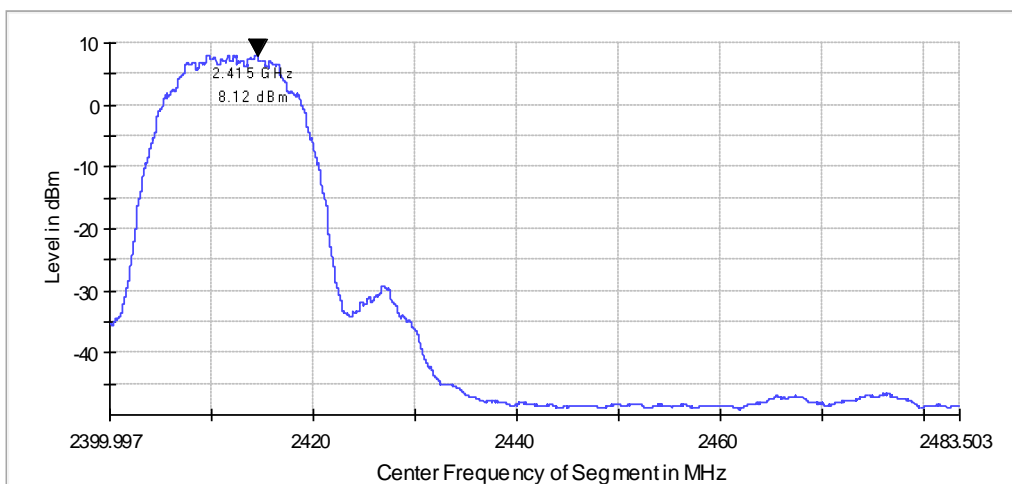

Plot A

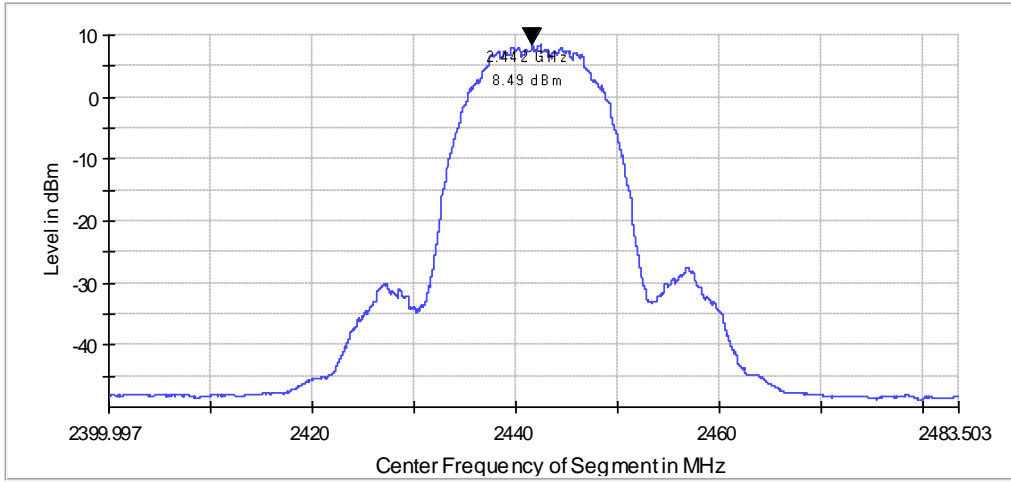

Plot B

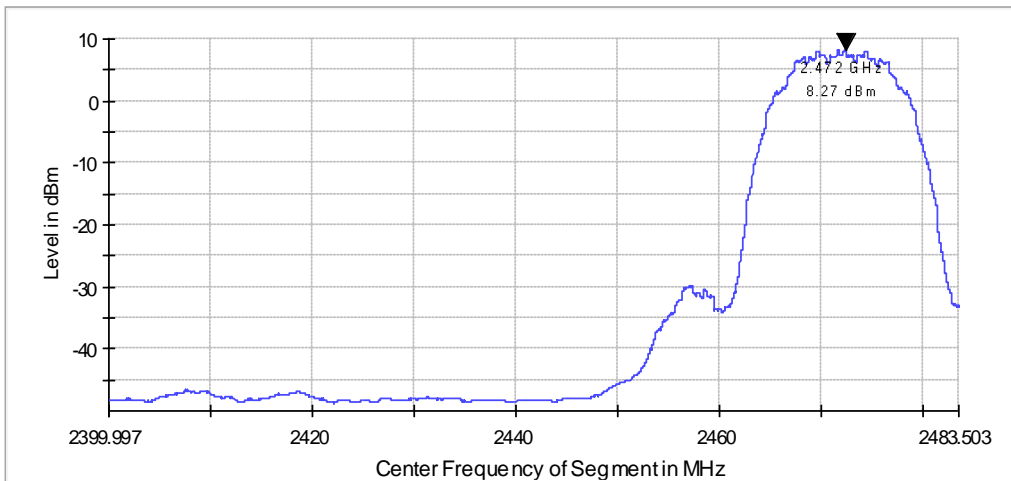

Plot C

2.2.4.2 802.11 g Mode

| Test Condition | Temperature:20°C , Voltage:3.3V | | | | |
|----------------|---------------------------------|-----------------------------------|-------------|---------------|------------|
| Channel | Frequency (MHz) | Center Frequency of Segment (MHz) | Level (dBm) | Refer to Plot | Limit(dBm) |
| 1 | 2412 | 2416.171513 | 2.3 | Plot D | <= 10 |
| 7 | 2442 | 2443.069921 | 2.6 | Plot E | |
| 13 | 2472 | 2473.073146 | 2.1 | Plot F | |
| Test Verdict | | PASS | | | |

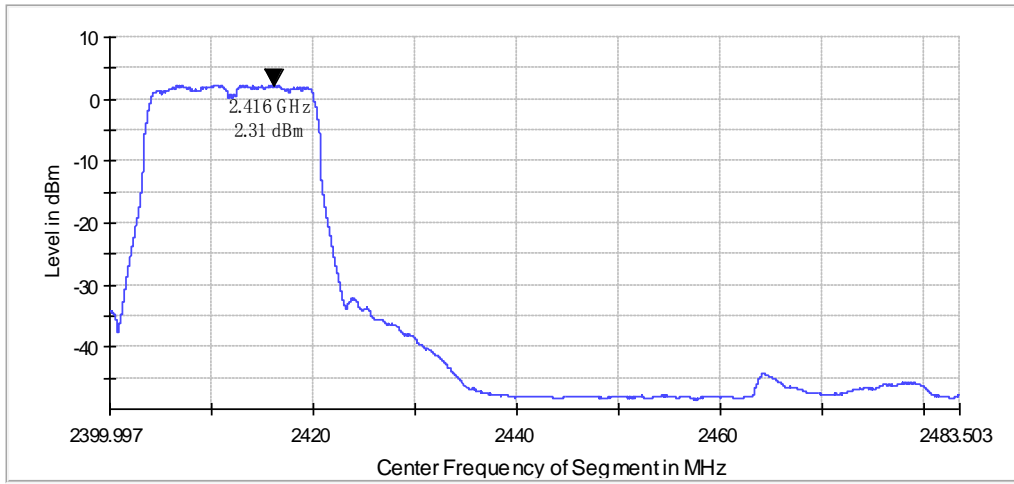

Plot D

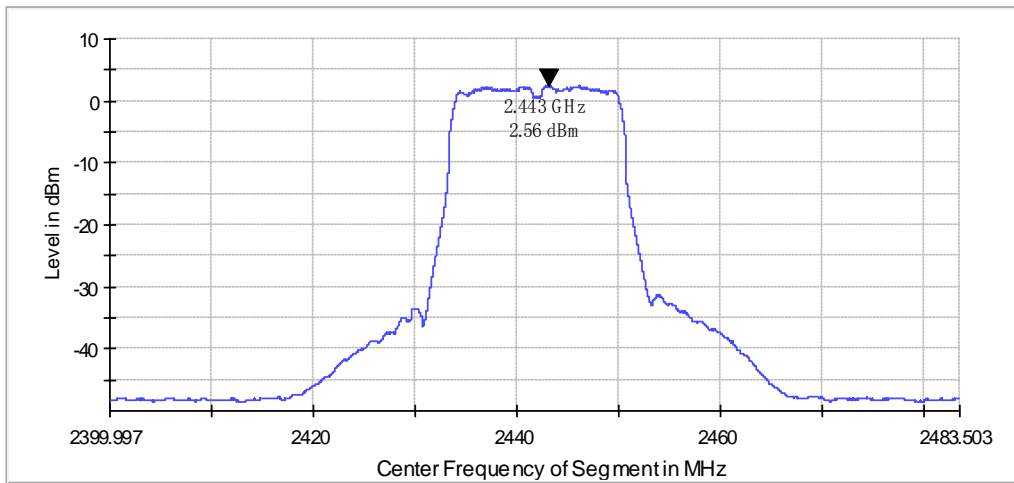

Plot E

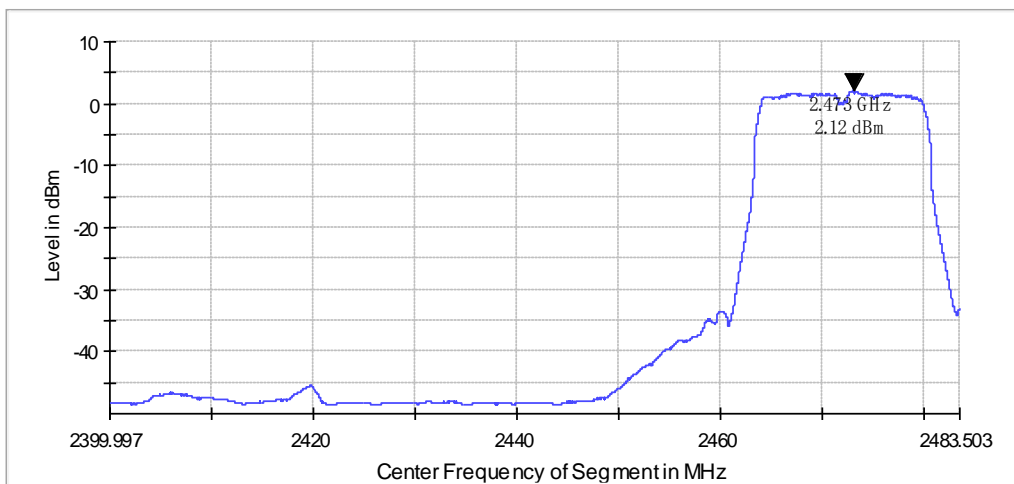

Plot F



2.2.4.3 802.11 n20 Mode

| Test Condition | Temperature:20°C , Voltage:3.3V | | | | |
|----------------|---------------------------------|-----------------------------------|-------------|---------------|------------|
| Channel | Frequency (MHz) | Center Frequency of Segment (MHz) | Level (dBm) | Refer to Plot | Limit(dBm) |
| 1 | 2412 | 2414.931586 | 0.8 | Plot G | <= 10 |
| 7 | 2442 | 2440.640065 | 1.0 | Plot H | |
| 13 | 2472 | 2473.398127 | 0.2 | Plot I | |
| Test Verdict | | PASS | | | |

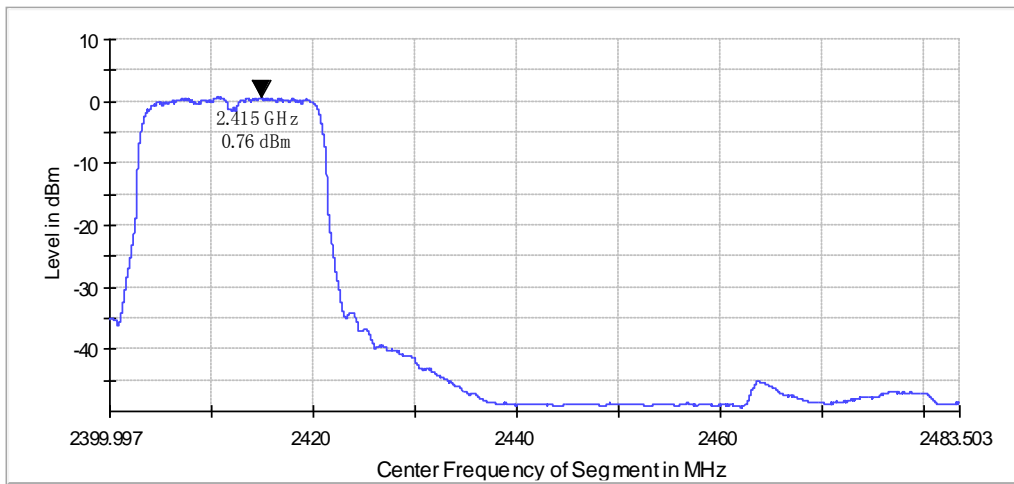

Plot G

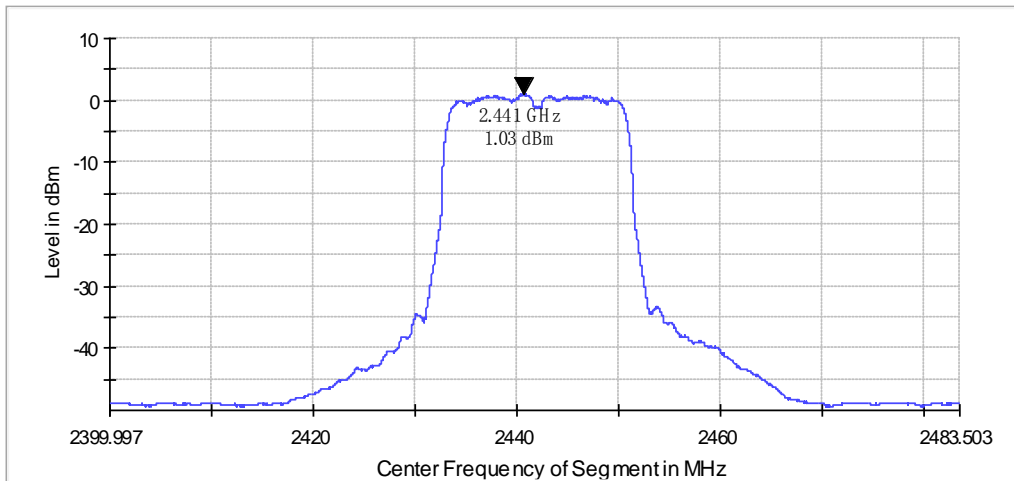

Plot H

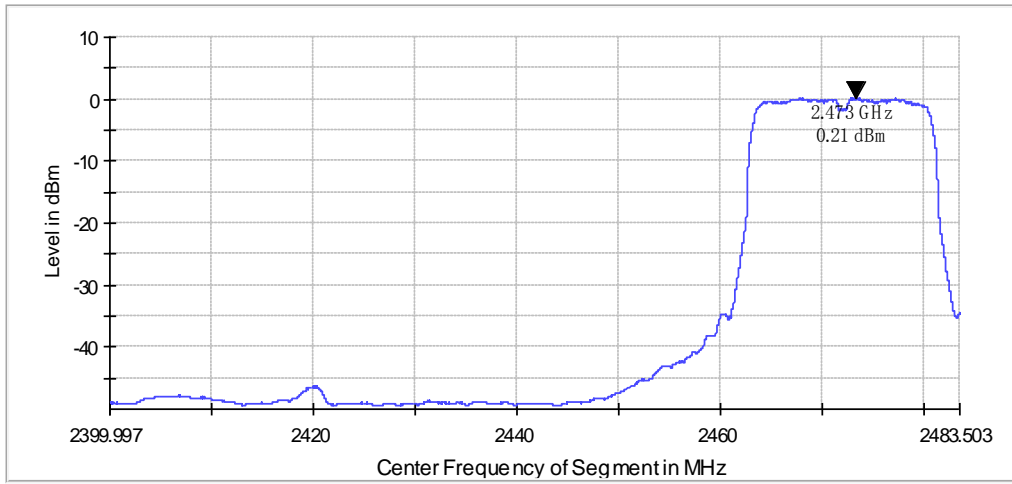

Plot I

2.2.4.4 802.11 n40 Mode

| Test Condition | Temperature:20°C , Voltage:3.3V | | | | |
|----------------|---------------------------------|-----------------------------------|-------------|---------------|-------------|
| Channel | Frequency (MHz) | Center Frequency of Segment (MHz) | Level (dBm) | Refer to Plot | Limit(d Bm) |
| 3 | 2422 | 2433.115510 | -3.2 | Plot J | <= 10 |
| 7 | 2442 | 2436.525309 | -3.5 | Plot K | |
| 11 | 2462 | 2456.524125 | -3.5 | Plot L | |
| Test Verdict | | PASS | | | |

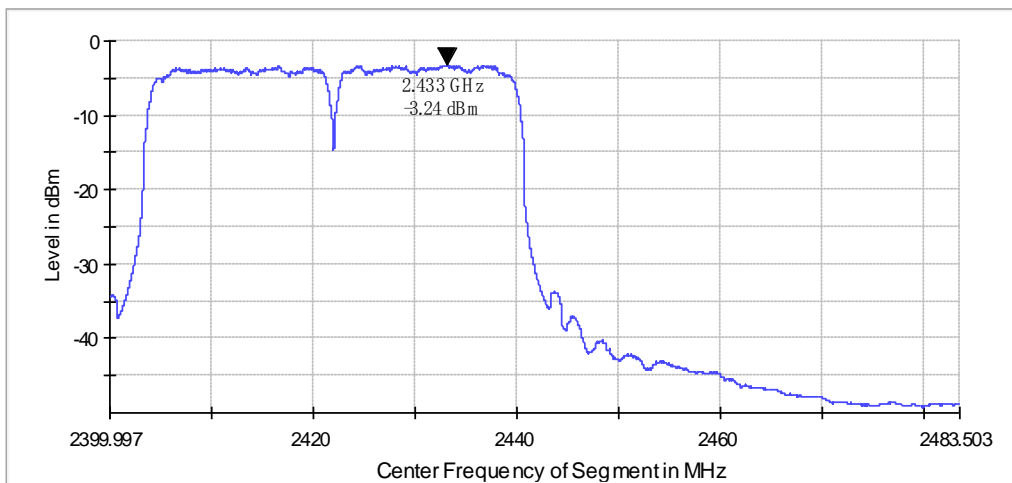

Plot J

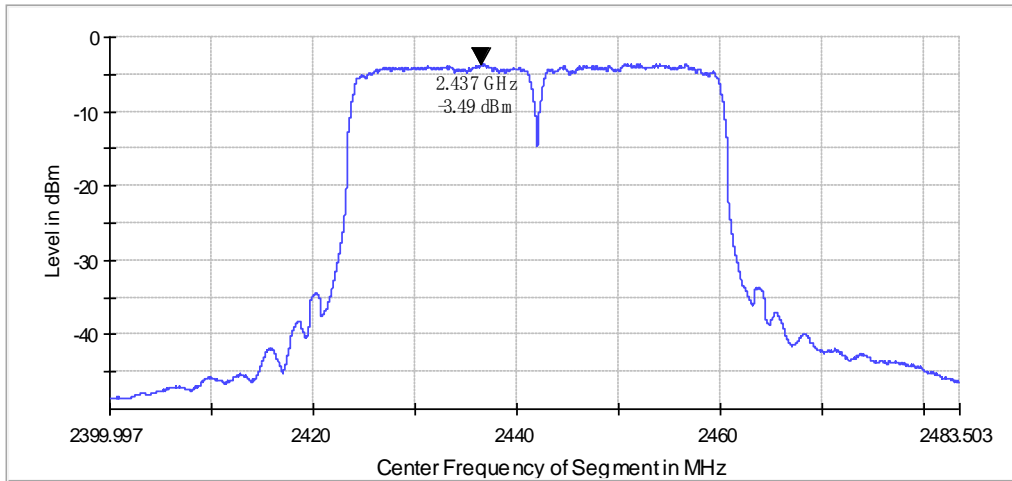

Plot K

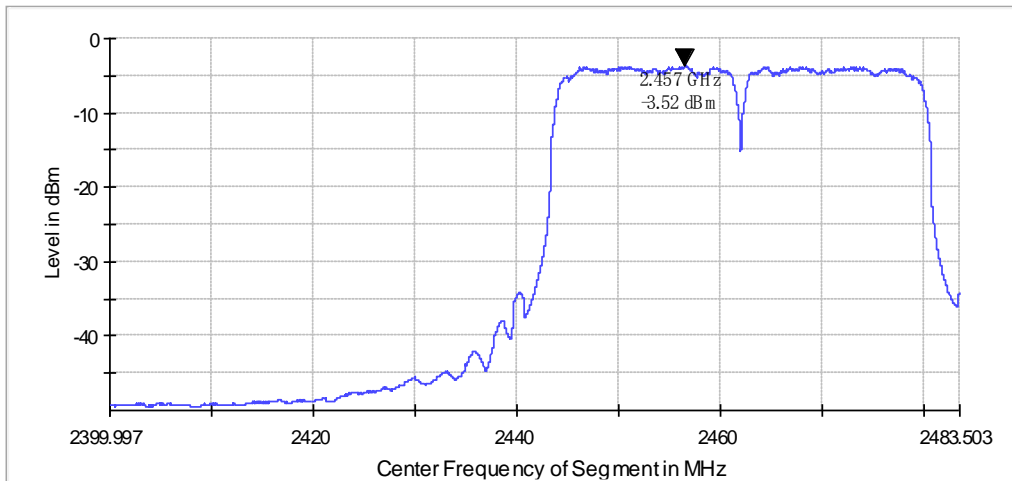

Plot L

| | |
|--------------|-------------|
| Temperature: | 20°C |
| Voltage: | 5V |
| Mode No.: | GWF-3M08-5V |

2.2.4.5 802.11 b Mode

| Test Condition | Temperature:20°C , Voltage:5V | | | | |
|----------------|-------------------------------|-----------------------------------|-------------|---------------|-------------|
| Channel | Frequency (MHz) | Center Frequency of Segment (MHz) | Level (dBm) | Refer to Plot | Limit(d Bm) |
| 1 | 2412 | 2409.536906 | 8.1 | Plot A1 | <= 10 |
| 7 | 2442 | 2442.474957 | 8.4 | Plot B1 | |
| 13 | 2472 | 2472.473182 | 8.2 | Plot C1 | |
| Test Verdict | | PASS | | | |

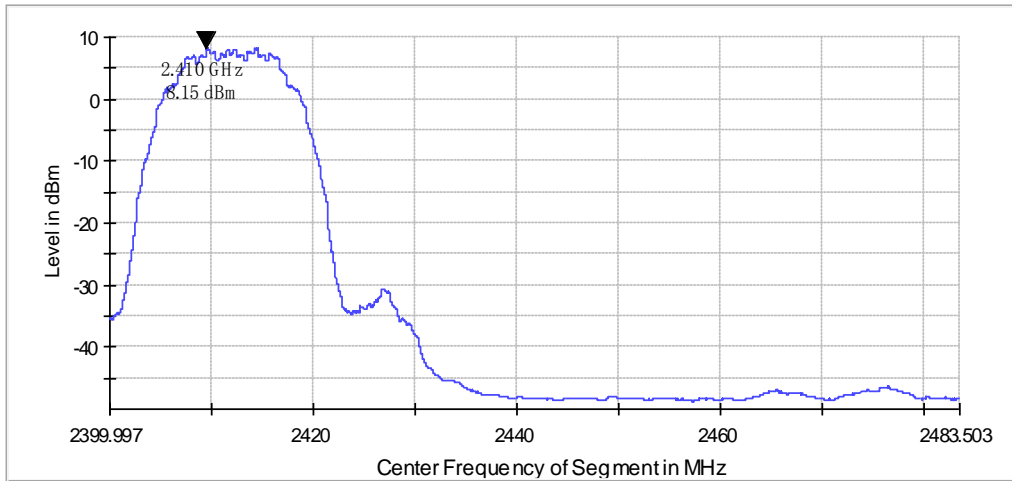

Plot A1

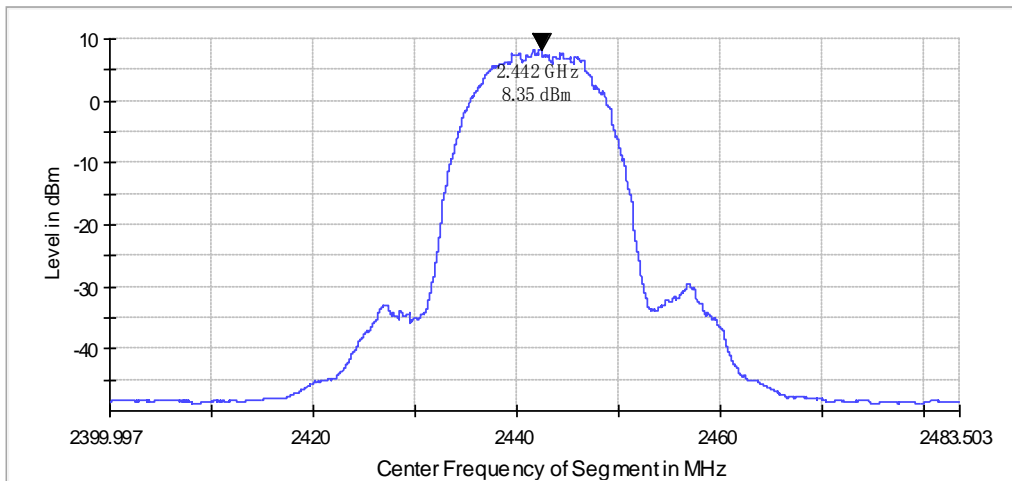

Plot B1

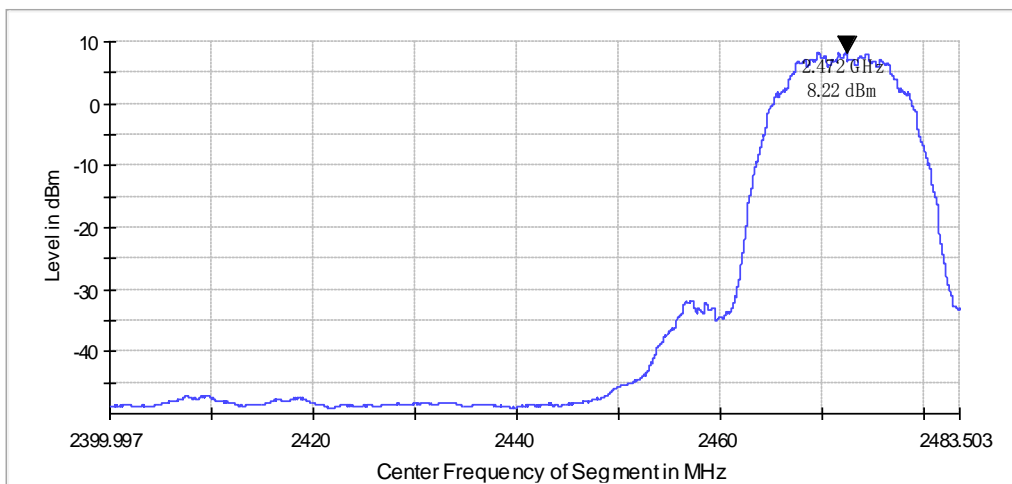

Plot C1





2.2.4.6 802.11 g Mode

| Test Condition | Temperature:20°C , Voltage:5V | | | | |
|----------------|-------------------------------|-----------------------------------|-------------|---------------|------------|
| Channel | Frequency (MHz) | Center Frequency of Segment (MHz) | Level (dBm) | Refer to Plot | Limit(dBm) |
| 1 | 2412 | 2416.166513 | 2.2 | Plot D1 | <= 10 |
| 7 | 2442 | 2443.094920 | 2.5 | Plot E1 | |
| 13 | 2472 | 2473.063147 | 2.5 | Plot F1 | |
| Test Verdict | | PASS | | | |

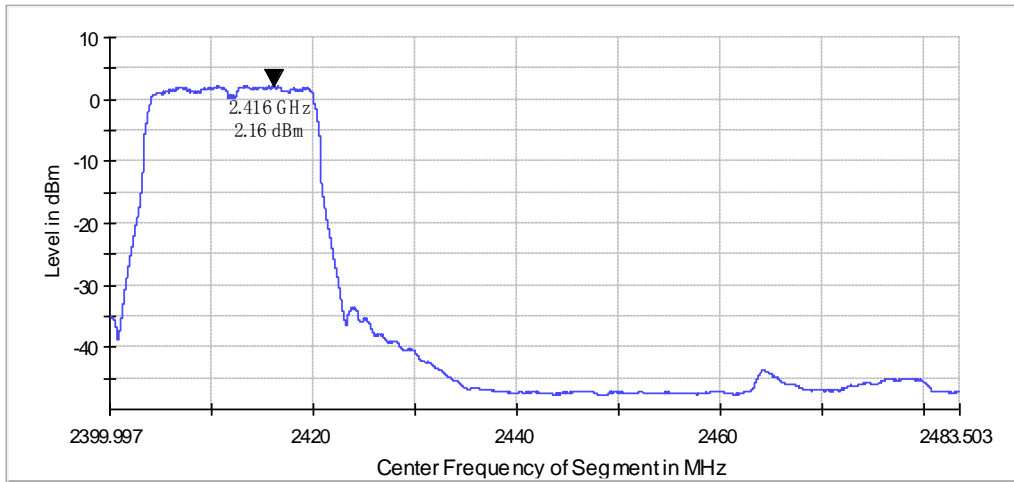

Plot D1

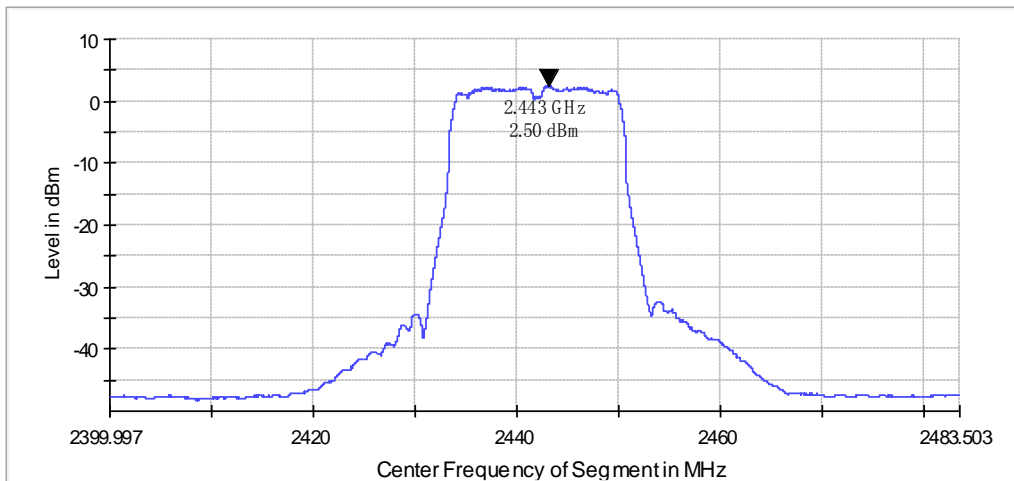

Plot E1

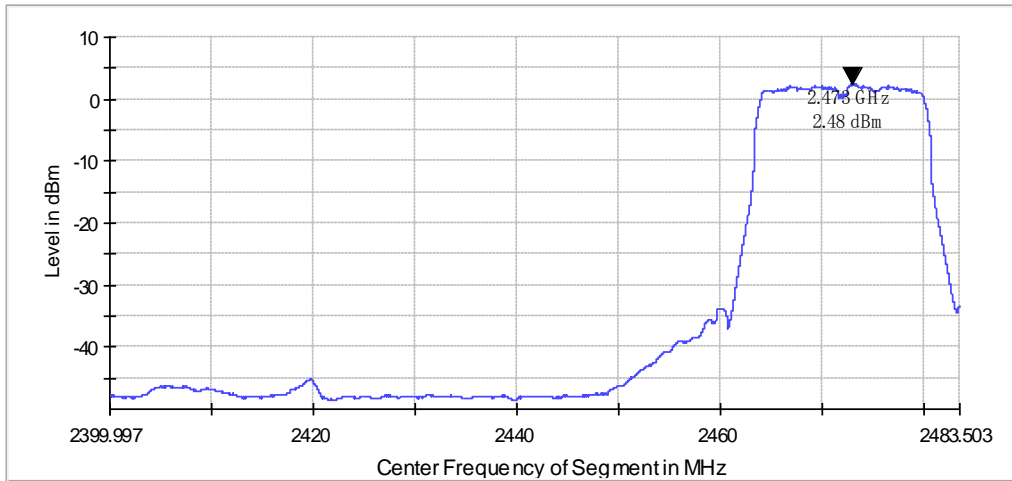

Plot F1

2.2.4.7 802.11 n20 Mode

| Test Condition | Temperature:20°C , Voltage:5V | | | | |
|----------------|-------------------------------|-----------------------------------|-------------|---------------|------------|
| Channel | Frequency (MHz) | Center Frequency of Segment (MHz) | Level (dBm) | Refer to Plot | Limit(dBm) |
| 1 | 2412 | 2410.631841 | 0.2 | Plot G1 | <= 10 |
| 7 | 2442 | 2440.595068 | 0.4 | Plot H1 | |
| 13 | 2472 | 2473.393127 | 0.6 | Plot I1 | |
| Test Verdict | | PASS | | | |

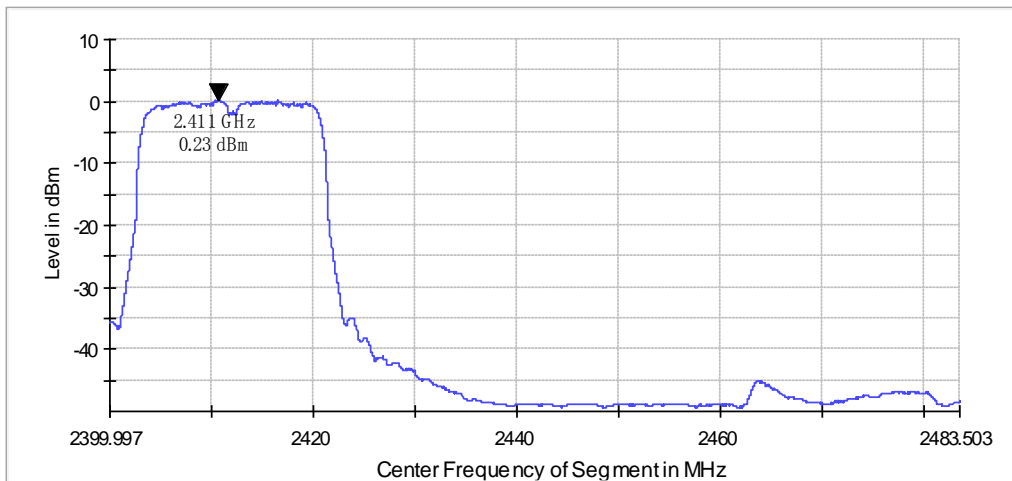

Plot G1

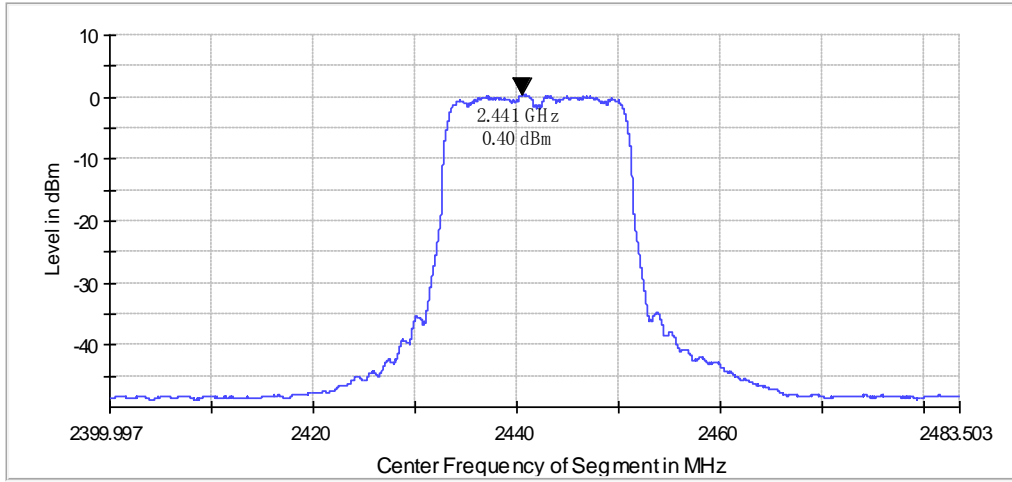

Plot H1

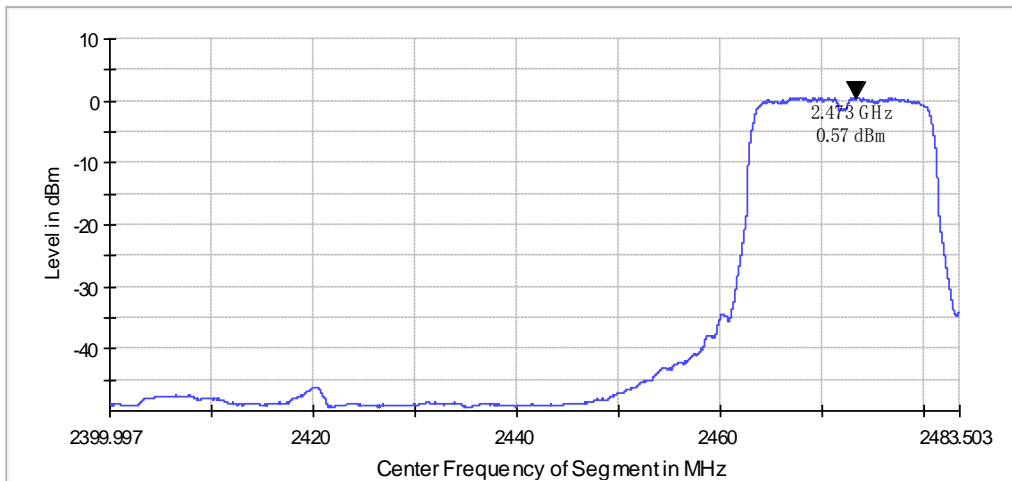

Plot I1

2.2.4.8 802.11 n40 Mode

| Test Condition | Temperature:20°C , Voltage:5V | | | | |
|----------------|-------------------------------|-----------------------------------|-------------|---------------|------------|
| Channel | Frequency (MHz) | Center Frequency of Segment (MHz) | Level (dBm) | Refer to Plot | Limit(dBm) |
| 3 | 2422 | 2433.110511 | -3.0 | Plot J1 | <= 10 |
| 7 | 2442 | 2450.909458 | -3.1 | Plot K1 | |
| 11 | 2462 | 2456.509126 | -3.1 | Plot L1 | |
| Test Verdict | | PASS | | | |

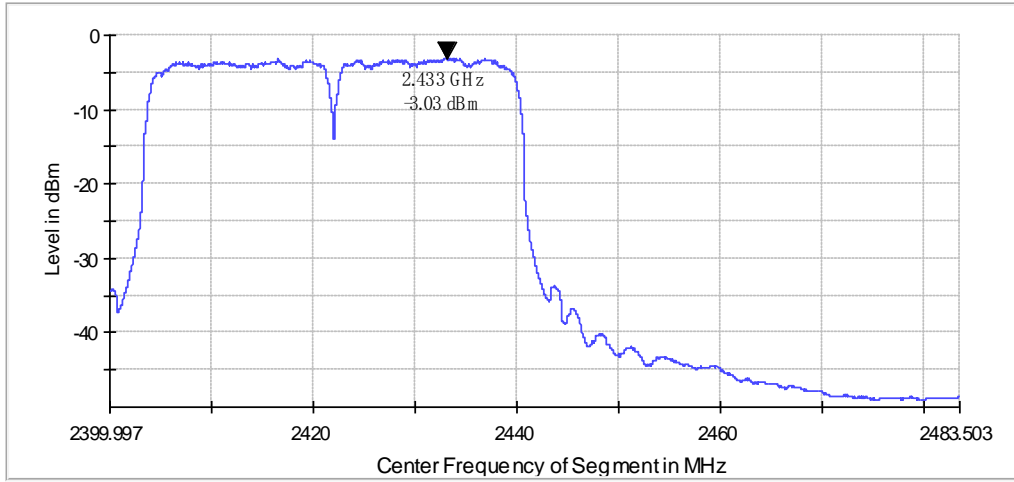

Plot J1

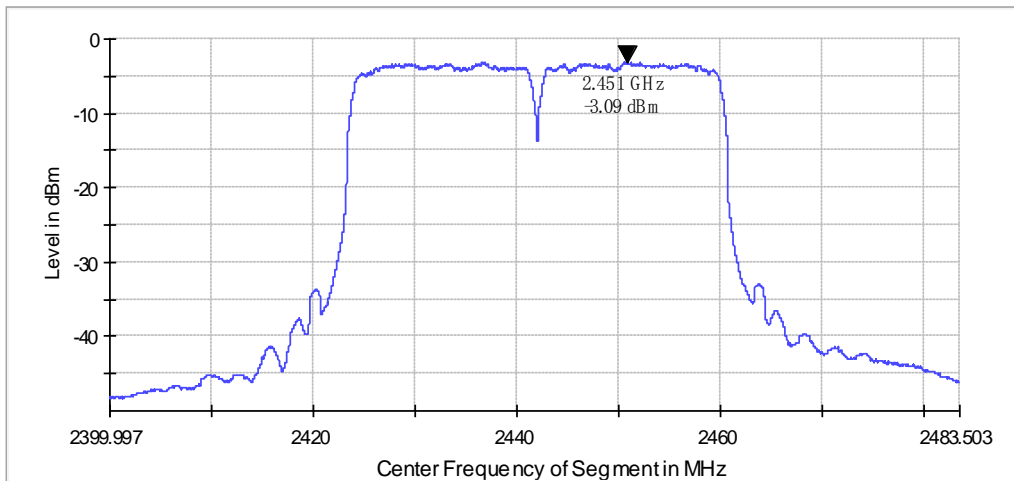

Plot K1

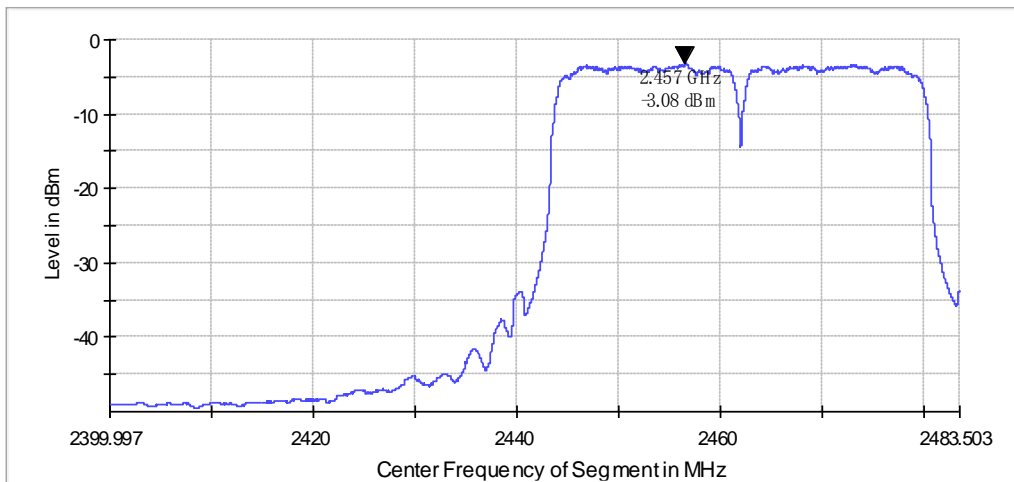

Plot L1

2.3. EN 300 328 §4.3.2.5 - Adaptivity

This requirement does not apply to non-adaptive equipment or adaptive equipment operating in a non-adaptive mode providing the equipment complies with the requirements and/or restrictions applicable to non-adaptive equipment.

In addition, this requirement does not apply for equipment with a maximum declared RF Output power level of less than 10 dBm e.i.r.p. or for equipment when operating in a mode where the RF Output power is less than 10 dBm e.i.r.p.

Adaptive equipment using modulations other than FHSS is allowed to operate in a non-adaptive mode providing it complies with the requirements applicable to non-adaptive equipment.

An adaptive equipment using modulations other than FHSS is equipment that uses a mechanism by which it can adapt to its environment by identifying other transmissions present within its Occupied Channel Bandwidth.

Adaptive equipment using modulations other than FHSS shall implement either of the Detect and Avoid mechanisms provided in clauses 4.3.2.5.1 or 4.3.2.5.2.

Adaptive systems are allowed to switch dynamically between different adaptive modes.

Short Control Signalling Transmissions are transmissions used by adaptive equipment to send control signals (e.g. ACK/NACK signals, etc.) without sensing the operating channel for the presence of other signals.

2.3.1. Test Limit

The EUT shall observe the operating channel for the duration of the CCA observation time which shall be not less than 20 μ s. (The CCA time used by the equipment shall be declared by the supplier.)

For Load Based Equipment, the EUT shall be verified that the EUT complies with maximum Channel Occupancy Time: $(13/32) \times q$ (ms). (The value of q is selected by the manufacturer in the range 4..32.)

If implemented, Short Control Signalling Transmissions of adaptive equipment using wide band modulations other than FHSS shall have a maximum duty cycle of 10 % within an observation period of 50 ms.

It shall also be verified (if necessary by repeating the test) that the Idle Period varies between CCA and $q \times CCA$.

Verification of reaction to the interference signal:

Using the procedure defined in clause 5.3.7.2.1.4, it shall be verified that,

- (1) The UUT shall stop transmissions on the current operating channel.
- (2) Apart from Short Control Signalling Transmissions, there shall be no subsequent transmissions while the interfering signal is present.
- (3) The UUT may continue to have Short Control Signalling Transmissions on the operating channel while the interfering signal is present.

2.3.2. Test Configuration

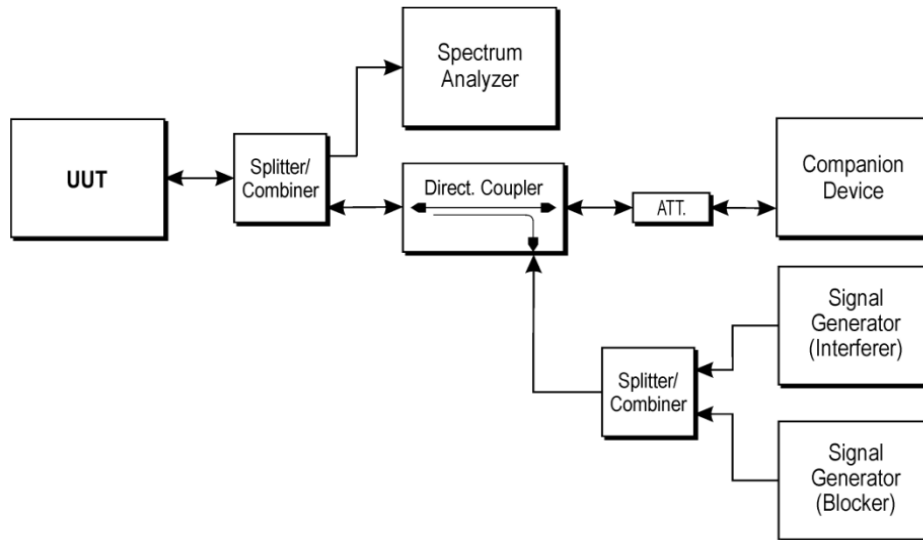

2.3.3. Test Procedure

Please refer to ETSI EN 300 328 (V1.8.1) Sub-clause 5.3.7 for the measurement method. The conducted measurement method was used in this report.

The different steps below define the procedure to verify the efficiency of the LBT based adaptive mechanism of equipment using wide band modulations other than FHSS. This method can be applied on Load Based Equipment and Frame Based Equipment.

Step 1:

- The UUT may connect to a companion device during the test. The interference signal generator, the blocking signal generator, the spectrum analyser, the UUT and the companion device are connected using a set-up equivalent to the example given by figure 5 although the interference and blocking signal generator do not generate any signals at this point in time. The spectrum analyser is used to monitor the transmissions of the UUT in response to the interfering and the blocking signals.

- Adjust the received signal level (wanted signal from the companion device) at the UUT to the value defined in table 6 (clause 4).

NOTE 1: Testing of Unidirectional equipment does not require a link to be established with a companion device.

- The analyzer shall be set as follows:

- RBW: \geq Occupied Channel Bandwidth (if the analyser does not support this setting, the highest available setting shall be used)
- VBW: $3 \times$ RBW (if the analyser does not support this setting, the highest available setting shall be used)

- Detector Mode: RMS
- Centre Frequency: Equal to the centre frequency of the operating channel
- Span: 0 Hz
- Sweep time: > maximum Channel Occupancy Time
- Trace Mode: Clear Write
- Trigger Mode: Video

Step 2:

•Configure the UUT for normal transmissions with a sufficiently high payload to allow demonstration of compliance of the adaptive mechanism on the channel being tested.

•For Frame Based Equipment, using the procedure defined in clause 5.3.7.2.1.4, it shall be verified that the UUT complies with the maximum Channel Occupancy Time and minimum Idle Period defined in clause 4.3.2.5.2.2.1.

•For Load Based equipment, using the procedure defined in clause 5.3.7.2.1.4, it shall be verified that the UUT complies with the maximum Channel Occupancy Time defined in clause 4.3.2.5.2.2.2. It shall also be verified (if necessary by repeating the test) that the Idle Period varies between CCA and $q \times \text{CCA}$ as defined in clause 4.3.2.5.2.2.2.

NOTE 2: For Load Based Equipment referred to in the first paragraph of clause 4.3.2.5.2.2.2 (IEEE 802.11 [i.3] or IEEE 802.15.4 [i.5] equipment), the minimum Idle Period and the maximum Channel Occupancy Time are as defined for other types of Load Based Equipment (see clause 4.3.2.5.2.2.2 points 2 and 3). The CCA observation time is declared by the supplier (see clause 5.3.1 d).

Step 3: Adding the interference signal

•A 100 % duty cycle interference signal is injected on the current operating channel of the UUT. This interference signal shall be a band limited noise signal which has a flat power spectral density, and shall have a bandwidth greater than the Occupied Channel Bandwidth of the UUT. The maximum ripple of this interfering signal shall be $\pm 1,5$ dB within the Occupied Channel Bandwidth and the power spectral density (at the input of the UUT) shall be as defined in clause 4.3.2.5.2.2.1 step 5 (frame based equipment) or clause 4.3.2.5.2.2.2 step 5 (load based equipment).

Step 4: Verification of reaction to the interference signal

•The spectrum analyser shall be used to monitor the transmissions of the UUT on the selected operating channel with the interfering signal injected. This may require the spectrum analyser sweep to be triggered by the start of the interfering signal.

• Using the procedure defined in clause 5.3.7.2.1.4, it shall be verified that:

i) The UUT shall stop transmissions on the current operating channel.

NOTE 3: The UUT is assumed to stop transmissions within a period equal to the maximum Channel Occupancy Time defined in clauses 4.3.2.5.2.2.1 (frame based equipment) or 4.3.2.5.2.2.2 (load based equipment).

ii) Apart from Short Control Signalling Transmissions, there shall be no subsequent transmissions while the interfering signal is present.

iii) The UUT may continue to have Short Control Signalling Transmissions on the operating channel while the interfering signal is present. These transmissions shall comply with the limits defined in clause 4.3.2.5.3.2.

NOTE 4: The verification of the Short Control Signalling transmissions may require the analyser settings to be changed (e.g. sweep time).

iv) Alternatively, the equipment may switch to a non-adaptive mode.

Step 5: Adding the blocking signal

•With the interfering signal present, a 100 % duty cycle CW signal is inserted as the blocking signal. The frequency and the level are provided in table 6 of clause 4.3.2.10.2.

• Repeat step 4 to verify that the UUT does not resume any normal transmissions.

Step 6: Removing the interference and blocking signal

•On removal of the interference and blocking signal the UUT is allowed to start transmissions again on this channel however this is not a requirement and therefore does not require testing.

Step 7:

•The steps 2 to 6 shall be repeated for each of the frequencies to be tested.

2.3.4. Test Result

| | |
|----------------|---|
| CCA Time | 20 μ s |
| Value q | 32 |
| Test Condition | Temperature 20 $^{\circ}$ C, Voltage 3.3V |
| Mode No. | GWF-3M08-3.3V |

RBW=10MHz VBW=10MHz Span=0Hz

802.11b mode

| DUT Frequency (MHz) | DUT Port | Test | Number of Bursts | Number of Bursts >10dBm | Max Burst Power | minimum Tx Off Time (ms) |
|---------------------|----------|------------------------------|------------------|-------------------------|-----------------|--------------------------|
| 2412.0000 | 1 | Interferer off / Blocker off | 56 | 10 | 20.0 | 0.196 |
| 2412.0000 | 1 | Interferer on / Blocker off | 0 | 0 | --- | --- |
| 2412.0000 | 1 | Interferer on / Blocker on | 1 | 0 | 8.2 | --- |
| 2472.0000 | 1 | Interferer off / Blocker off | 58 | 22 | 20.0 | 0.054 |
| 2472.0000 | 1 | Interferer on / Blocker off | 144 | 0 | 2.5 | --- |
| 2472.0000 | 1 | Interferer on / Blocker on | 0 | 0 | --- | --- |

| DUT Frequency | Maximum Tx Sequence Time | Result | Comment |
|---------------|--------------------------|--------|--------------------------------|
| 2412.0000 | 1.324 | PASS | Sequence < 13 ms |
| 2412.0000 | --- | PASS | Power < 10dBm; no bursts found |
| 2412.0000 | --- | PASS | Power < 10dBm |



| | | | |
|-----------|-------|------|------------------|
| 2472.0000 | 1.212 | PASS | Sequence < 13 ms |
| 2472.0000 | --- | PASS | Power < 10dBm |
| 2472.0000 | --- | PASS | Power < 10dBm |

| DUT Frequency(MHz) | Blocking signal frequency(MHz) | Blocking signal power(dBm) | Type of interfering signal |
|--------------------|--------------------------------|----------------------------|----------------------------|
| 2412 | 2488.5 | -30 | CW |
| 2472 | 2395 | -30 | |

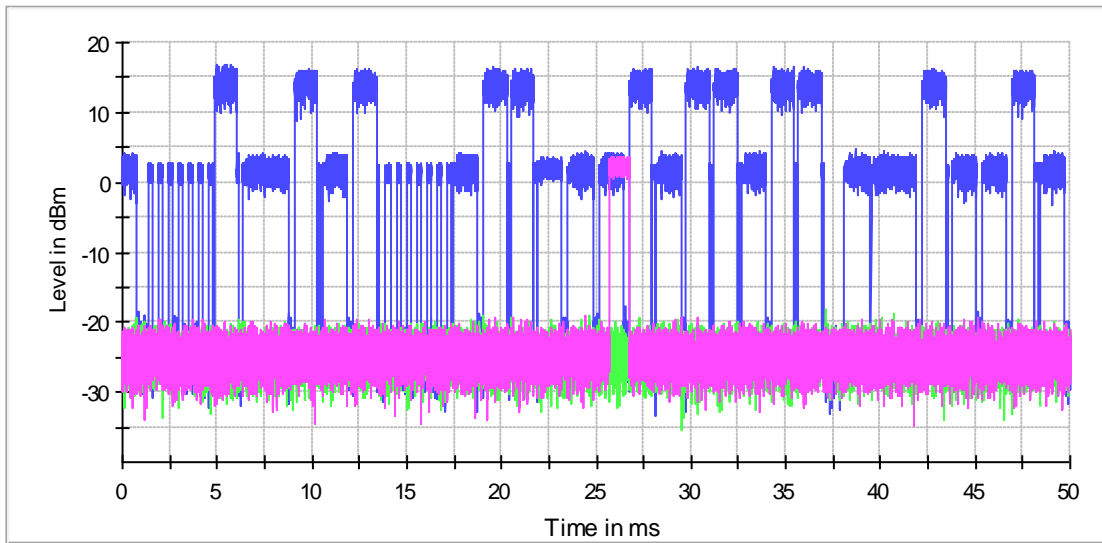

— Interferer off / Blocker off — Interferer on / Blocker off — Interferer on / Blocker on

802.11b_1ch

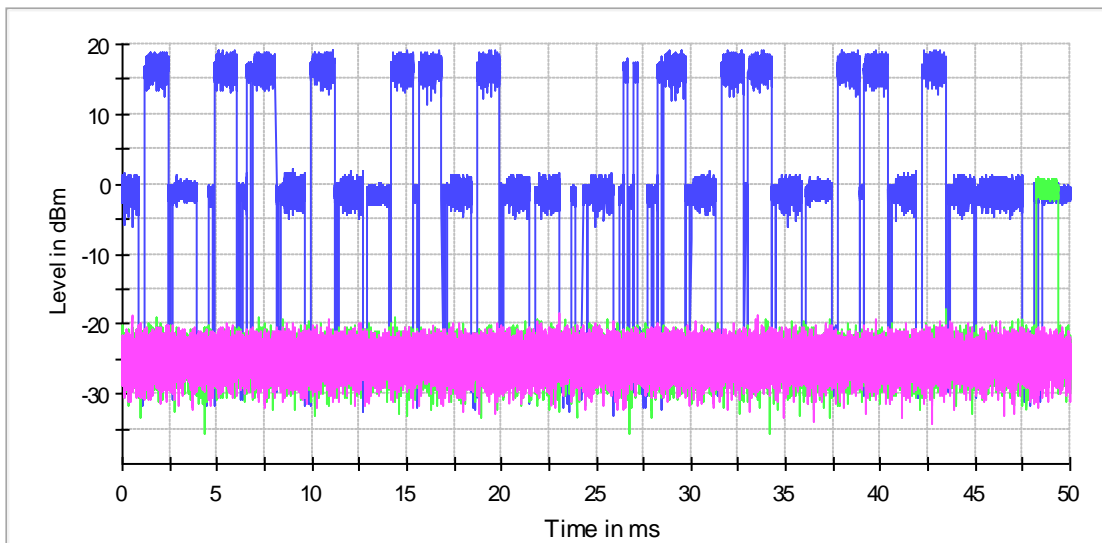

— Interferer off / Blocker off — Interferer on / Blocker off — Interferer on / Blocker on

802.11b_13ch



802.11g mode

| DUT Frequency (MHz) | DUT Port | Test | Number of Bursts | Number of Bursts >10dBm | Max Burst Power | minimum Tx Off Time (ms) |
|---------------------|----------|------------------------------|------------------|-------------------------|-----------------|--------------------------|
| 2412.0000 | 1 | Interferer off / Blocker off | 192 | 68 | 20.0 | 0.028 |
| 2412.0000 | 1 | Interferer on / Blocker off | 1 | 1 | 14.9 | --- |
| 2412.0000 | 1 | Interferer on / Blocker on | 0 | 0 | --- | --- |
| 2472.0000 | 1 | Interferer off / Blocker off | 212 | 90 | 20.0 | 0.032 |
| 2472.0000 | 1 | Interferer on / Blocker off | 2 | 1 | 17.5 | --- |
| 2472.0000 | 1 | Interferer on / Blocker on | 218 | 0 | 7.6 | --- |

| DUT Frequency | Maximum Tx Sequence Time | Result | Comment |
|---------------|--------------------------|--------|--|
| 2412.0000 | 1.226 | PASS | Sequence < 13 ms |
| 2412.0000 | 0.084 | PASS | Burst < 5 ms; Short Signaling ok; TX switch off time < 15 ms |
| 2412.0000 | --- | PASS | Power < 10dBm; no bursts found |
| 2472.0000 | 0.232 | PASS | Sequence < 13 ms |
| 2472.0000 | 0.048 | PASS | Burst < 5 ms; Short Signaling ok; TX switch off time < 15 ms |
| 2472.0000 | --- | PASS | Power < 10dBm |

| DUT Frequency(MHz) | Blocking signal frequency(MHz) | Blocking signal power(dBm) | Type of interfering signal |
|--------------------|--------------------------------|----------------------------|----------------------------|
| 2412 | 2488.5 | -30 | CW |
| 2472 | 2395 | -30 | |

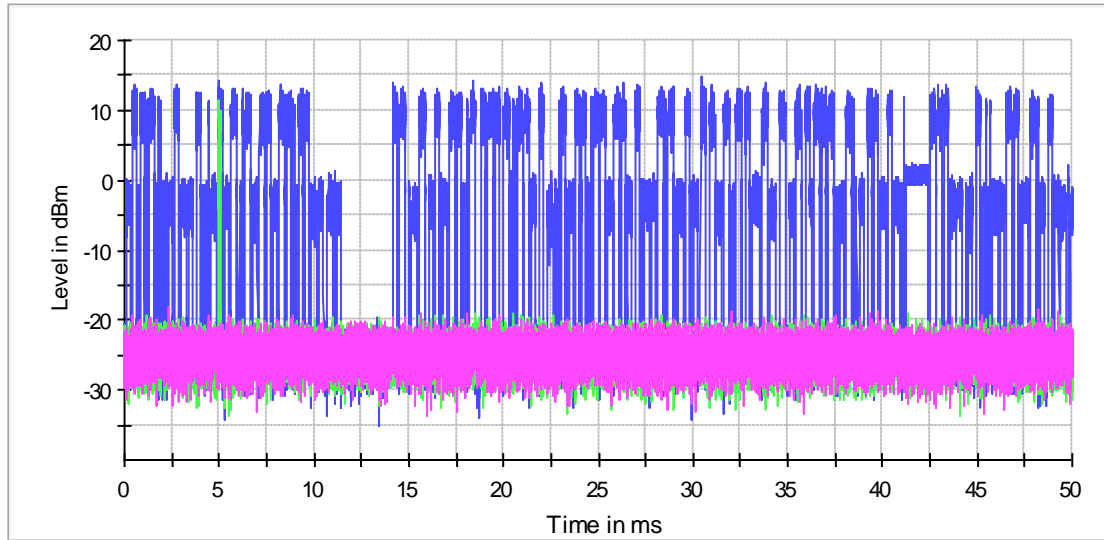

— Interferer off / Blocker off
 — Interferer on / Blocker off
 — Interferer on / Blocker on

802.11g_1ch

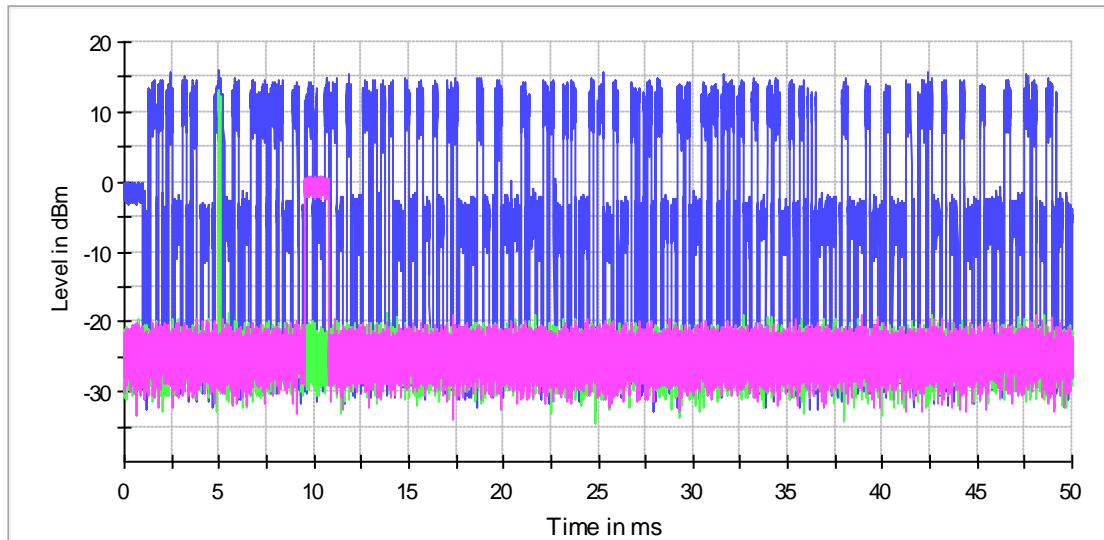

— Interferer off / Blocker off
 — Interferer on / Blocker off
 — Interferer on / Blocker on

802.11g_13ch

802.11n20 mode

| DUT Frequency (MHz) | DUT Port | Test | Number of Bursts | Number of Bursts >10dBm | Max Burst Power (dBm) | minimum Tx Off Time (ms) |
|---------------------|----------|------------------------------|------------------|-------------------------|-----------------------|--------------------------|
| 2412.0000 | 1 | Interferer off / Blocker off | 146 | 52 | 20.0 | 0.002 |
| 2412.0000 | 1 | Interferer on / Blocker off | 0 | 0 | --- | --- |
| 2412.0000 | 1 | Interferer on / Blocker on | 0 | 0 | --- | --- |

| | | | | | | |
|-----------|---|---------------------------------|-----|----|------|-------|
| 2472.0000 | 1 | Interferer off / Blocker off | 150 | 48 | 20.0 | 0.000 |
| 2472.0000 | 1 | Interferer on / Blocker off | 0 | 0 | --- | --- |
| 2472.0000 | 1 | Interferer on / Blocker on | 0 | 0 | --- | --- |

| DUT Frequency | Maximum Tx Sequence Time | Result | Comment |
|------------------|-----------------------------|--------|--------------------------------|
| 2412.0000 | 1.142 | PASS | Sequence < 13 ms |
| 2412.0000 | --- | PASS | Power < 10dBm; no bursts found |
| 2412.0000 | --- | PASS | Power < 10dBm; no bursts found |
| 2472.0000 | 1.130 | PASS | Sequence < 13 ms |
| 2472.0000 | --- | PASS | Power < 10dBm; no bursts found |
| 2472.0000 | --- | PASS | Power < 10dBm; no bursts found |

| DUT Frequency(MHz) | Blocking signal frequency(MHz) | Blocking signal power(dBm) | Type of interfering signal |
|-----------------------|-----------------------------------|-------------------------------|-------------------------------|
| 2412 | 2488.5 | -30 | CW |
| 2472 | 2395 | -30 | |

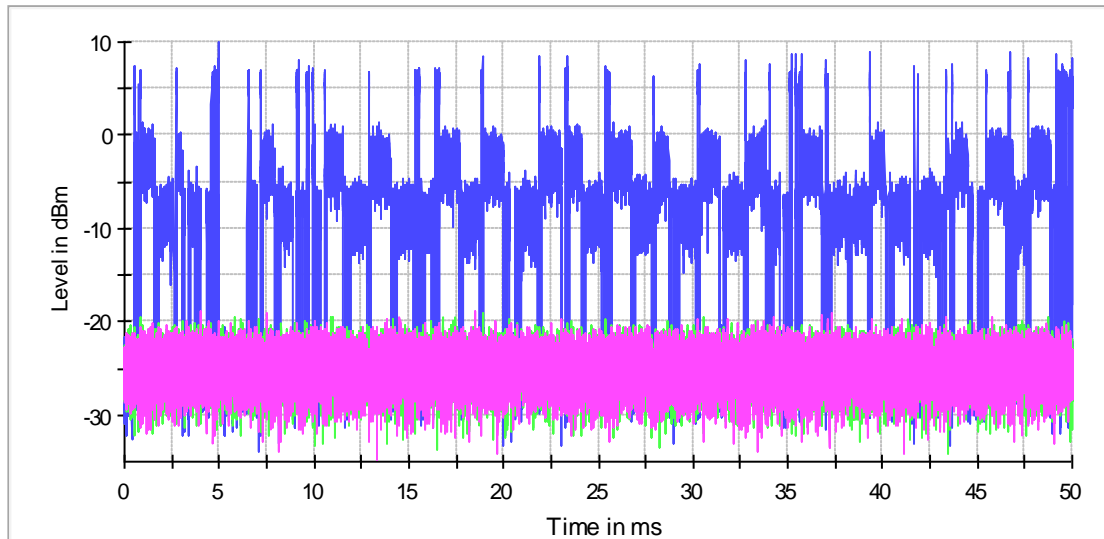

— Interferer off / Blocker off
 — Interferer on / Blocker off
 — Interferer on / Blocker on

802.11n20_1ch

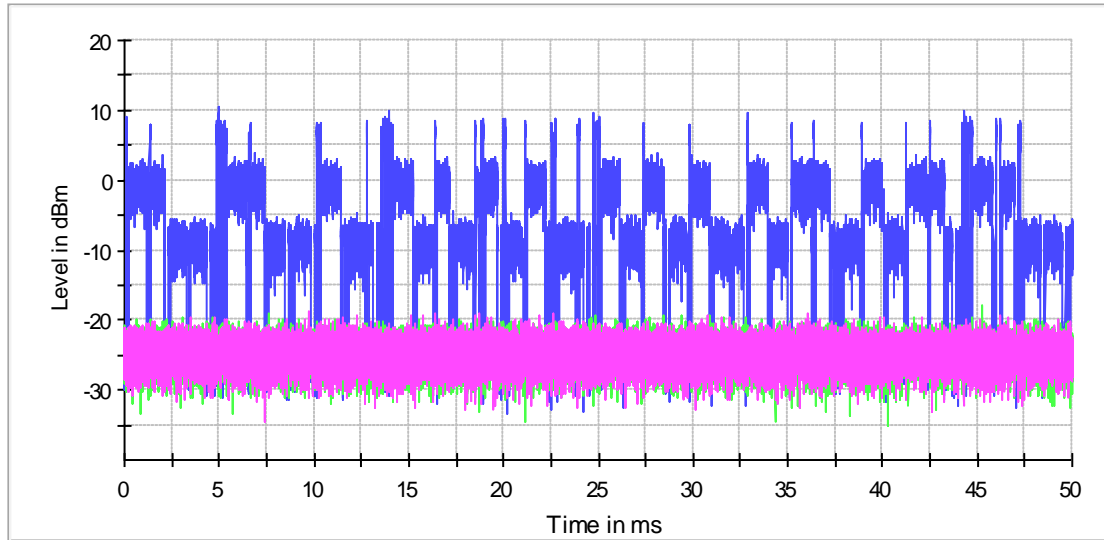

— Interferer off / Blocker off
 — Interferer on / Blocker off
 — Interferer on / Blocker on

802.11n20_13ch

802.11n40 mode

| DUT Frequency (MHz) | DUT Port | Test | Number of Bursts | Number of Bursts >10dBm | Max Burst Power | minimum Tx Off Time (ms) |
|---------------------|----------|------------------------------|------------------|-------------------------|-----------------|--------------------------|
| 2422.0000 | 1 | Interferer off / Blocker off | 98 | 34 | 20.0 | 0.000 |
| 2422.0000 | 1 | Interferer on / Blocker off | 6 | 2 | 13.1 | 9.912 |
| 2422.0000 | 1 | Interferer on / Blocker on | 1 | 1 | 16.4 | --- |
| 2462.0000 | 1 | Interferer off / Blocker off | 92 | 36 | 20.0 | 0.003 |
| 2462.0000 | 1 | Interferer on / Blocker off | 1 | 1 | 16.4 | --- |
| 2462.0000 | 1 | Interferer on / Blocker on | 0 | 0 | --- | --- |

| DUT Frequency | Maximum Tx Sequence Time | Result | Comment |
|---------------|--------------------------|--------|--------------------------------------|
| 2422.0000 | 2.160 | PASS | Sequence < 13 ms |
| 2422.0000 | 1.612 | PASS | Burst < 5 ms; Short Signaling ok; TX |
| 2422.0000 | 0.100 | PASS | Burst < 5 ms; Short Signaling ok |
| 2462.0000 | 2.122 | PASS | Sequence < 13 ms |
| 2462.0000 | 0.190 | PASS | Burst < 5 ms; Short Signaling ok; TX |
| 2462.0000 | --- | PASS | Power < 10dBm; no bursts found |

| DUT Frequency(MHz) | Blocking signal frequency(MHz) | Blocking signal power(dBm) | Type of interfering signal |
|--------------------|--------------------------------|----------------------------|----------------------------|
| 2412 | 2488.5 | -30 | CW |
| 2472 | 2395 | -30 | |

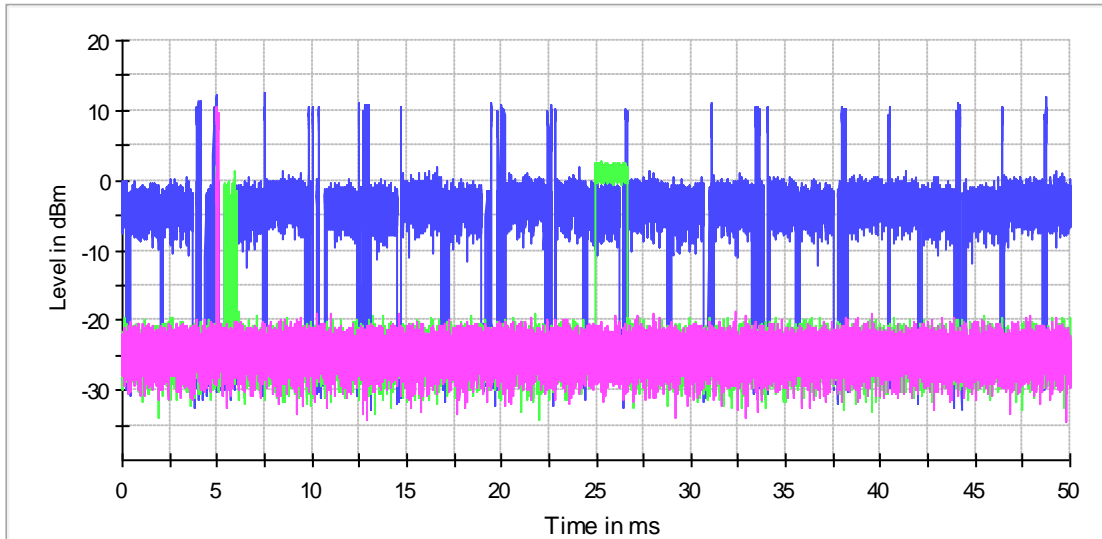

— Interferer off / Blocker off
 — Interferer on / Blocker off
 — Interferer on / Blocker on

802.11n40_3ch

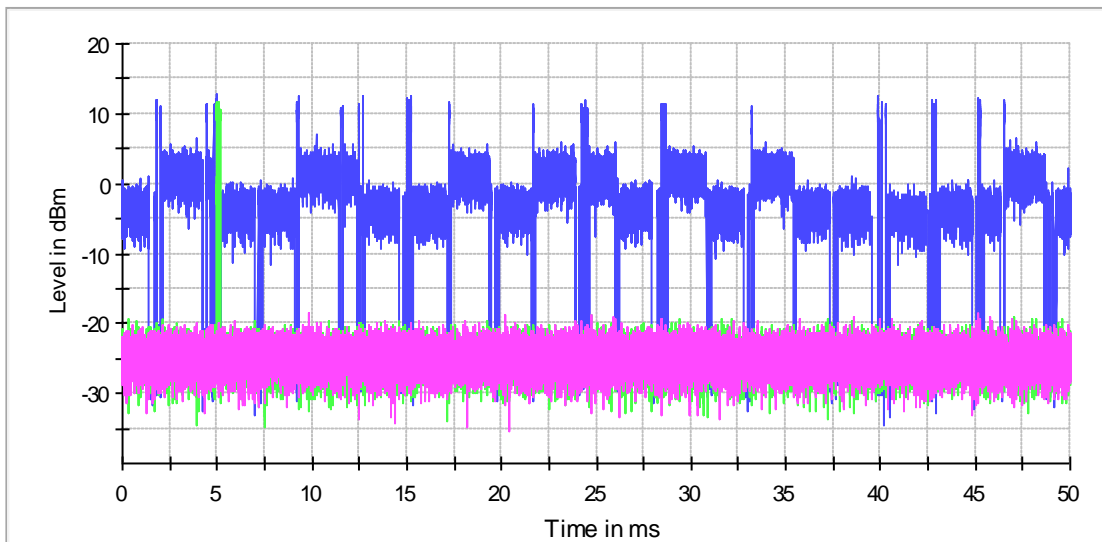

— Interferer off / Blocker off
 — Interferer on / Blocker off
 — Interferer on / Blocker on

802.11n40_11ch



| | |
|----------------|-------------------------------|
| CCA Time | 20 μs |
| Value q | 32 |
| Test Condition | Temperature 20 °C, Voltage 5V |
| Mode No. | GWF-3M08-5V |

RBW=10MHz VBW=10MHz Span=0Hz

802.11b mode

| DUT Frequency (MHz) | DUT Port | Test | Number of Bursts | Number of Bursts >10dBm | Max Burst Power | minimum Tx Off Time (ms) |
|---------------------|----------|------------------------------|------------------|-------------------------|-----------------|--------------------------|
| 2412.0000 | 1 | Interferer off / Blocker off | 45 | 8 | 20.0 | 0.182 |
| 2412.0000 | 1 | Interferer on / Blocker off | 0 | 0 | --- | --- |
| 2412.0000 | 1 | Interferer on / Blocker on | 1 | 0 | 8.2 | --- |
| 2472.0000 | 1 | Interferer off / Blocker off | 50 | 11 | 20.0 | 0.050 |
| 2472.0000 | 1 | Interferer on / Blocker off | 132 | 0 | 2.5 | --- |
| 2472.0000 | 1 | Interferer on / Blocker on | 0 | 0 | --- | --- |

| DUT Frequency | Maximum Tx Sequence Time | Result | Comment |
|---------------|--------------------------|--------|--------------------------------|
| 2412.0000 | 1.268 | PASS | Sequence < 13 ms |
| 2412.0000 | --- | PASS | Power < 10dBm; no bursts found |
| 2412.0000 | --- | PASS | Power < 10dBm |
| 2472.0000 | 1.212 | PASS | Sequence < 13 ms |
| 2472.0000 | --- | PASS | Power < 10dBm |
| 2472.0000 | --- | PASS | Power < 10dBm |

| DUT Frequency(MHz) | Blocking signal frequency(MHz) | Blocking signal power(dBm) | Type of interfering signal |
|--------------------|--------------------------------|----------------------------|----------------------------|
| 2412 | 2488.5 | -30 | CW |
| 2472 | 2395 | -30 | |

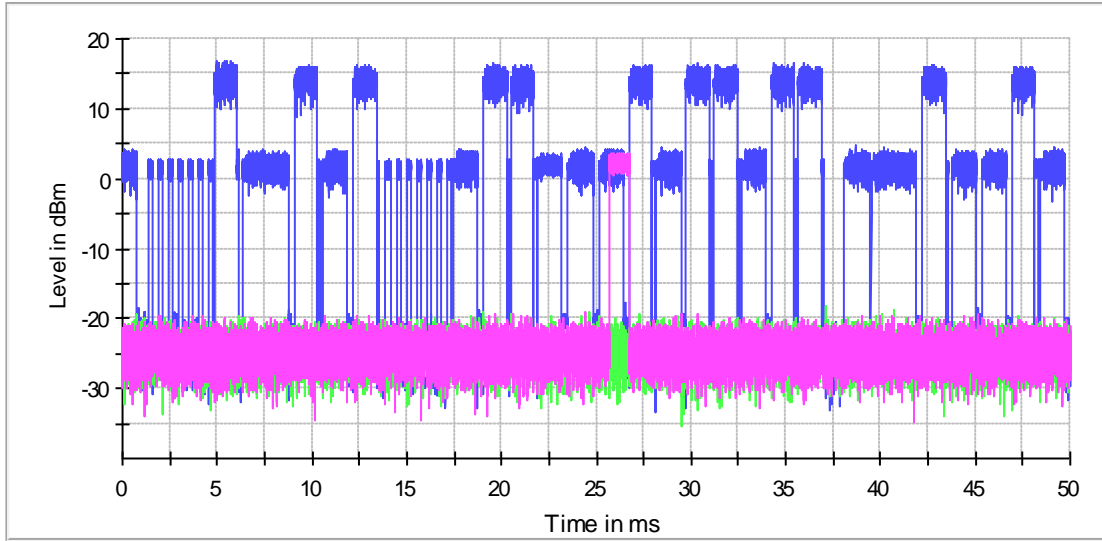

— Interferer off / Blocker off — Interferer on / Blocker off — Interferer on / Blocker on

802.11b_1ch

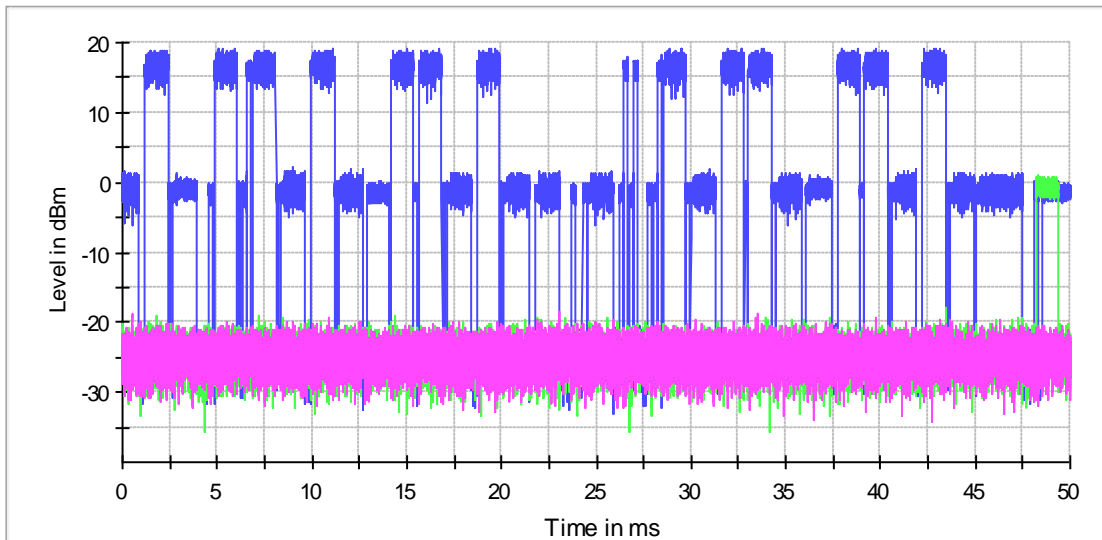

— Interferer off / Blocker off — Interferer on / Blocker off — Interferer on / Blocker on

802.11b_13ch

802.11g mode

| DUT Frequency (MHz) | DUT Port | Test | Number of Bursts | Number of Bursts >10dBm | Max Burst Power | minimum Tx Off Time (ms) |
|---------------------|----------|------------------------------|------------------|-------------------------|-----------------|--------------------------|
| 2412.0000 | 1 | Interferer off / Blocker off | 188 | 74 | 20.0 | 0.023 |
| 2412.0000 | 1 | Interferer on / Blocker off | 1 | 1 | 14.9 | --- |
| 2412.0000 | 1 | Interferer on / | 0 | 0 | --- | --- |

| | | Blocker on | | | | |
|-----------|---|---------------------------------|-----|----|------|-------|
| 2472.0000 | 1 | Interferer off / Blocker off | 202 | 90 | 20.0 | 0.037 |
| 2472.0000 | 1 | Interferer on / Blocker off | 2 | 1 | 17.5 | --- |
| 2472.0000 | 1 | Interferer on / Blocker on | 198 | 0 | 7.6 | --- |

| DUT Frequency | Maximum Tx Sequence Time | Result | Comment |
|---------------|--------------------------|--------|--|
| 2412.0000 | 1.212 | PASS | Sequence < 13 ms |
| 2412.0000 | 0.096 | PASS | Burst < 5 ms; Short Signaling ok; TX switch off time < 15 ms |
| 2412.0000 | --- | PASS | Power < 10dBm; no bursts found |
| 2472.0000 | 0.224 | PASS | Sequence < 13 ms |
| 2472.0000 | 0.048 | PASS | Burst < 5 ms; Short Signaling ok; TX switch off time < 15 ms |
| 2472.0000 | --- | PASS | Power < 10dBm |

| DUT Frequency(MHz) | Blocking signal frequency(MHz) | Blocking signal power(dBm) | Type of interfering signal |
|--------------------|--------------------------------|----------------------------|----------------------------|
| 2412 | 2488.5 | -30 | CW |
| 2472 | 2395 | -30 | |

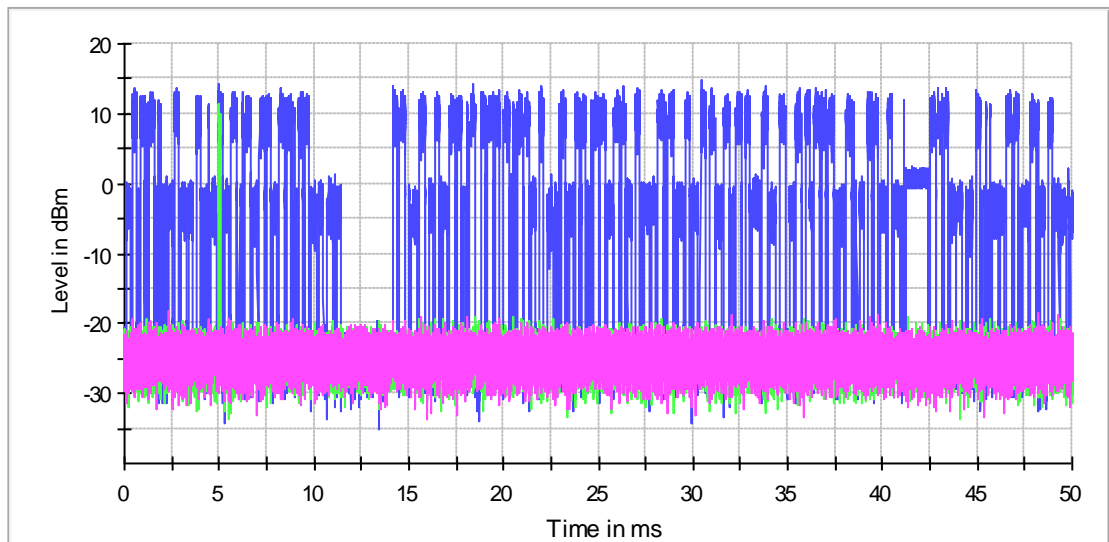

— Interferer off / Blocker off
 — Interferer on / Blocker off
 — Interferer on / Blocker on

802.11g_1ch

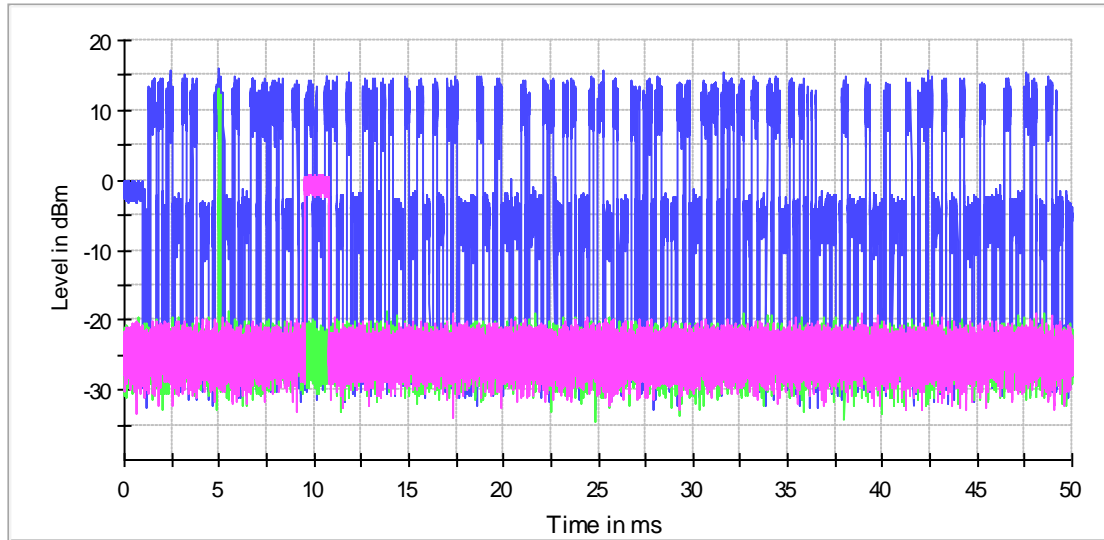

— Interferer off / Blocker off
 — Interferer on / Blocker off
 — Interferer on / Blocker on

802.11g_13ch

802.11n20 mode

| DUT Frequency (MHz) | DUT Port | Test | Number of Bursts | Number of Bursts >10dBm | Max Burst Power (dBm) | minimum Tx Off Time (ms) |
|---------------------|----------|------------------------------|------------------|-------------------------|-----------------------|--------------------------|
| 2412.0000 | 1 | Interferer off / Blocker off | 120 | 45 | 20.0 | 0.002 |
| 2412.0000 | 1 | Interferer on / Blocker off | 0 | 0 | --- | --- |
| 2412.0000 | 1 | Interferer on / Blocker on | 0 | 0 | --- | --- |
| 2472.0000 | 1 | Interferer off / Blocker off | 118 | 61 | 20.0 | 0.000 |
| 2472.0000 | 1 | Interferer on / Blocker off | 0 | 0 | --- | --- |
| 2472.0000 | 1 | Interferer on / Blocker on | 0 | 0 | --- | --- |

| DUT Frequency | Maximum Tx Sequence Time | Result | Comment |
|---------------|--------------------------|--------|--------------------------------|
| 2412.0000 | 1.204 | PASS | Sequence < 13 ms |
| 2412.0000 | --- | PASS | Power < 10dBm; no bursts found |
| 2412.0000 | --- | PASS | Power < 10dBm; no bursts found |
| 2472.0000 | 1.128 | PASS | Sequence < 13 ms |
| 2472.0000 | --- | PASS | Power < 10dBm; no bursts found |



| | | | |
|-----------|-----|------|--------------------------------|
| 2472.0000 | --- | PASS | Power < 10dBm; no bursts found |
|-----------|-----|------|--------------------------------|

| DUT Frequency(MHz) | Blocking signal frequency(MHz) | Blocking signal power(dBm) | Type of interfering signal |
|--------------------|--------------------------------|----------------------------|----------------------------|
| 2412 | 2488.5 | -30 | CW |
| 2472 | 2395 | -30 | |

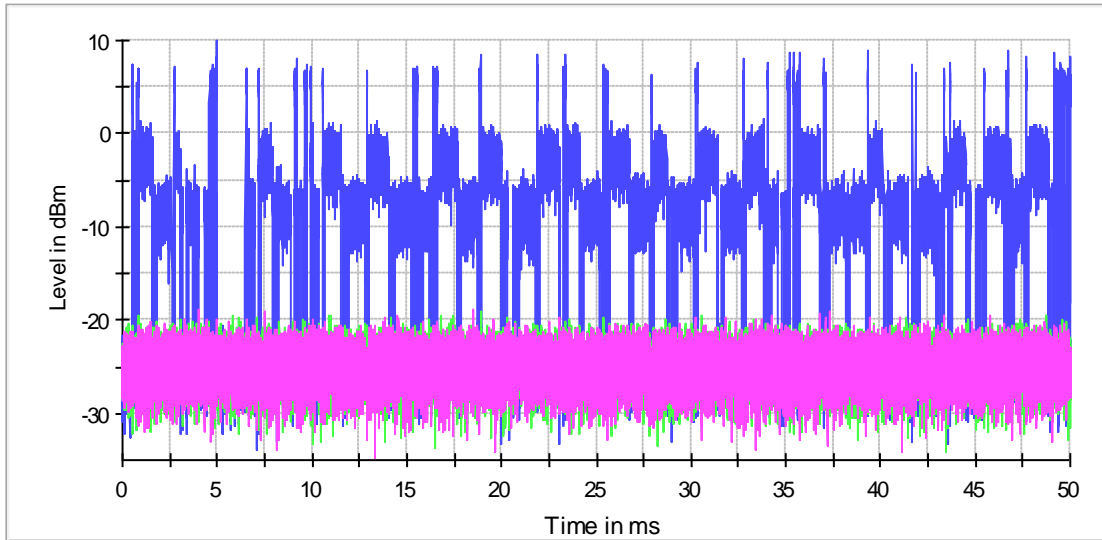

— Interferer off / Blocker off — Interferer on / Blocker off — Interferer on / Blocker on

802.11n20_1ch

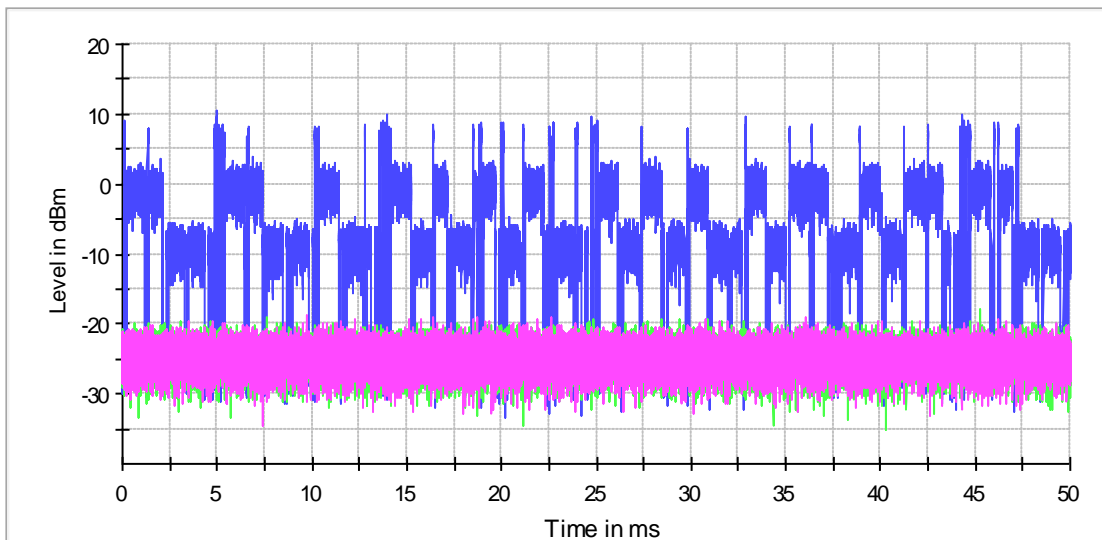

— Interferer off / Blocker off — Interferer on / Blocker off — Interferer on / Blocker on

802.11n20_13ch





802.11n40 mode

| DUT Frequency (MHz) | DUT Port | Test | Number of Bursts | Number of Bursts >10dBm | Max Burst Power | minimum Tx Off Time (ms) |
|---------------------|----------|------------------------------|------------------|-------------------------|-----------------|--------------------------|
| 2422.0000 | 1 | Interferer off / Blocker off | 134 | 40 | 20.0 | 0.000 |
| 2422.0000 | 1 | Interferer on / Blocker off | 9 | 2 | 13.1 | 19.920 |
| 2422.0000 | 1 | Interferer on / Blocker on | 1 | 1 | 16.4 | --- |
| 2462.0000 | 1 | Interferer off / Blocker off | 78 | 24 | 20.0 | 0.003 |
| 2462.0000 | 1 | Interferer on / Blocker off | 1 | 1 | 16.4 | --- |
| 2462.0000 | 1 | Interferer on / Blocker on | 0 | 0 | --- | --- |

| DUT Frequency | Maximum Tx Sequence Time | Result | Comment |
|---------------|--------------------------|--------|--------------------------------------|
| 2422.0000 | 2.122 | PASS | Sequence < 13 ms |
| 2422.0000 | 1.408 | PASS | Burst < 5 ms; Short Signaling ok; TX |
| 2422.0000 | 0.108 | PASS | Burst < 5 ms; Short Signaling ok |
| 2462.0000 | 2.101 | PASS | Sequence < 13 ms |
| 2462.0000 | 0.190 | PASS | Burst < 5 ms; Short Signaling ok; TX |
| 2462.0000 | --- | PASS | Power < 10dBm; no bursts found |

| DUT Frequency(MHz) | Blocking signal frequency(MHz) | Blocking signal power(dBm) | Type of interfering signal |
|--------------------|--------------------------------|----------------------------|----------------------------|
| 2412 | 2488.5 | -30 | CW |
| 2472 | 2395 | -30 | |

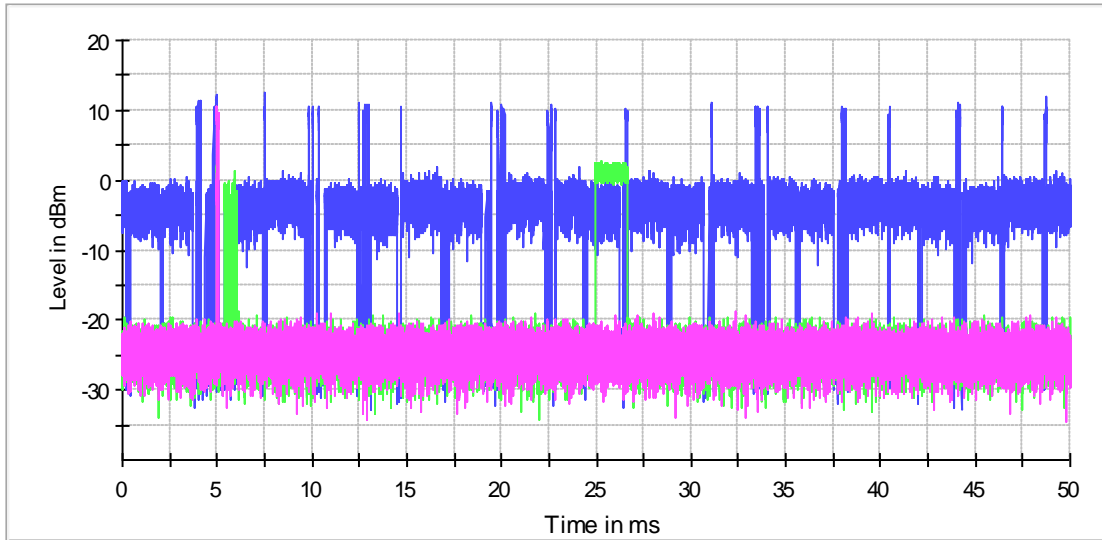

— Interferer off / Blocker off — Interferer on / Blocker off — Interferer on / Blocker on

802.11n40_3ch

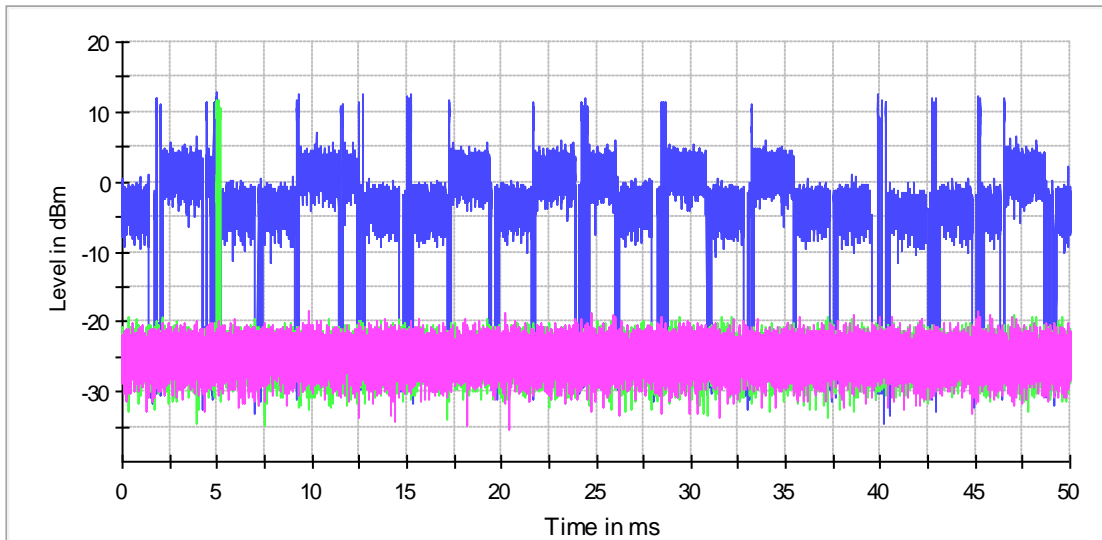

— Interferer off / Blocker off — Interferer on / Blocker off — Interferer on / Blocker on

802.11n40_11ch



2.4. EN 300 328 §4.3.2.6 - Occupied Channel Bandwidth

The Occupied Channel Bandwidth is the bandwidth that contains 99 % of the power of the signal.

2.4.1. Test Limit

The Occupied Channel Bandwidth for each hopping frequency shall fall completely within the band 2400MHz to 2483.5MHz.

2.4.2. Test Configuration

Please refer to 2.2.2

2.4.3. Test procedure

Please refer to ETSI EN 300 328 (V1.8.1) Sub-clause 5.3.8 for the measurement method.

The conducted measurement method was used in this report.

The measurement shall be performed only on the lowest and the highest frequency within the stated frequency range. The frequencies on which the test were performed shall be recorded.

If the equipment can operate with different Occupied Channel Bandwidths (e.g. 20 MHz and 40 MHz), then each channel bandwidth shall be tested separately.

The measurement procedure shall be as follows:

Step 1:

Connect the UUT to the spectrum analyser and use the following settings:

- Centre Frequency: The centre frequency of the channel under test
- Resolution BW: ~ 1 % of the span without going below 1 %
- Video BW: 3 × RBW
- Frequency Span: 2 × Occupied Channel Bandwidth (e.g. 40 MHz for a 20 MHz channel)
- Detector Mode: RMS
- Trace Mode: Max Hold

Step 2:

Wait until the trace is completed.

Find the peak value of the trace and place the analyser marker on this peak.

Step 3:

Use the 99 % bandwidth function of the spectrum analyser to measure the Occupied Channel Bandwidth of the UUT.

This value shall be recorded.

NOTE: Make sure that the power envelope is sufficiently above the noise floor of the analyser to avoid the noise signals left and right from the power envelope being taken into account by this measurement.

2.4.4. Test Result

| | |
|--------------|---------------|
| Temperature: | 20°C |
| Voltage: | 3.3V |
| Mode No.: | GWF-3M08-3.3V |

| Test Condition | Temperature 20 °C, Voltage 3.3V | | | | |
|------------------|---------------------------------|----------------------------------|-----------------------|-----------------------|---------------|
| Mode and channel | Channel center Frequency(MHz) | Occupied Channel Bandwidth (MHz) | Lower Band Edge (MHz) | Upper Band Edge (MHz) | Refer to plot |
| 802.11 b(1ch) | 2412.015092 | 15.076748 | 2404.476718 | 2419.553466 | Plot A |
| 802.11 b(13ch) | 2471.984649 | 15.058046 | 2464.455626 | 2479.513672 | Plot B |
| 802.11 g(1ch) | 2411.990740 | 17.377286 | 2403.302097 | 2420.679384 | Plot C |
| 802.11 g(13ch) | 2471.968384 | 17.371739 | 2463.282514 | 2480.654253 | Plot D |
| 802.11 n20(1ch) | 2412.024824 | 18.215221 | 2402.917214 | 2421.132435 | Plot E |
| 802.11 n20(13ch) | 2472.002823 | 18.213613 | 2462.896016 | 2481.109629 | Plot F |
| 802.11 n40(3ch) | 2422.052546 | 36.391560 | 2403.856766 | 2440.248326 | Plot G |
| 802.11n40(11ch) | 2462.013694 | 36.390903 | 2443.818242 | 2480.209146 | Plot H |
| Test Verdict | PASS | | | | |

802.11b: RBW=300kHz VBW=1MHz Span(refer to plot)

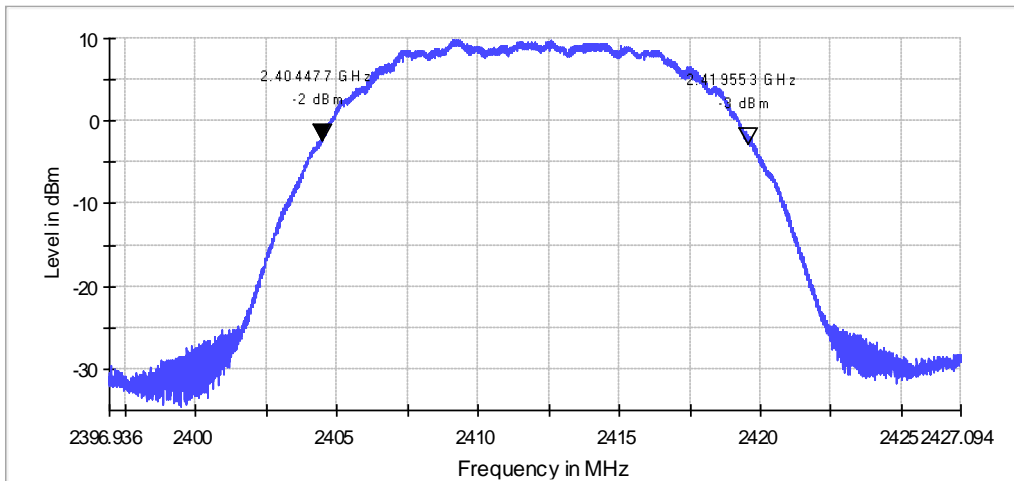

Plot A

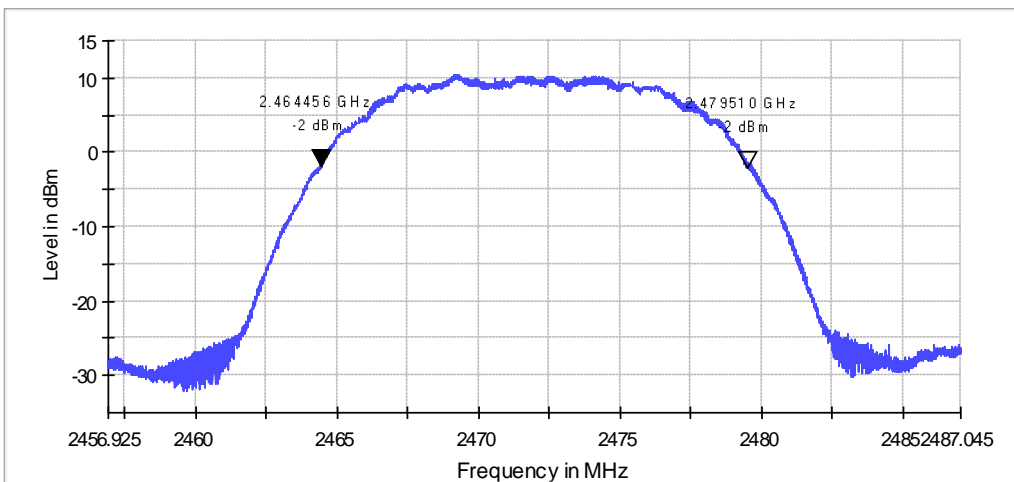

Plot B

802.11g: RBW=1MHz VBW=3MHz Span(refer to plot)

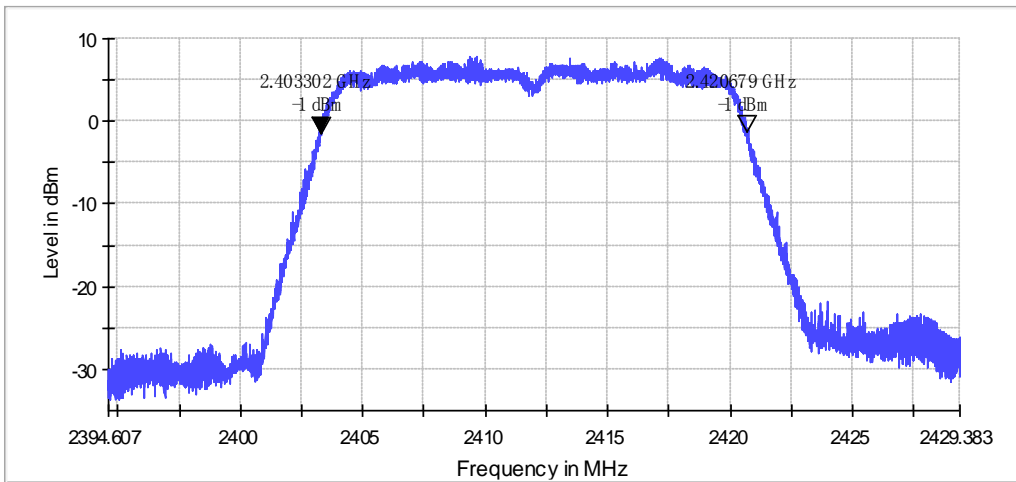

Plot C

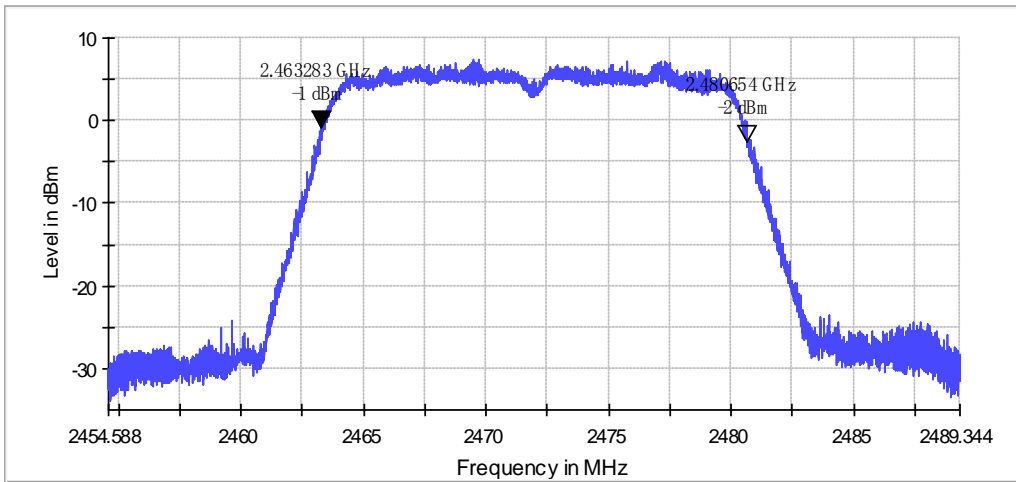

Plot D

802.11n20: RBW=1MHz VBW=3MHz Span(refer to plot)

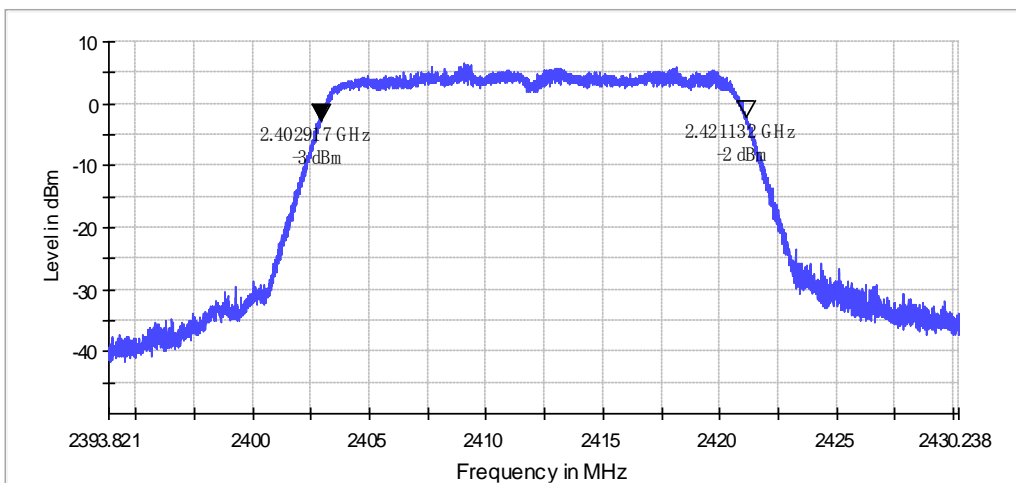

Plot E

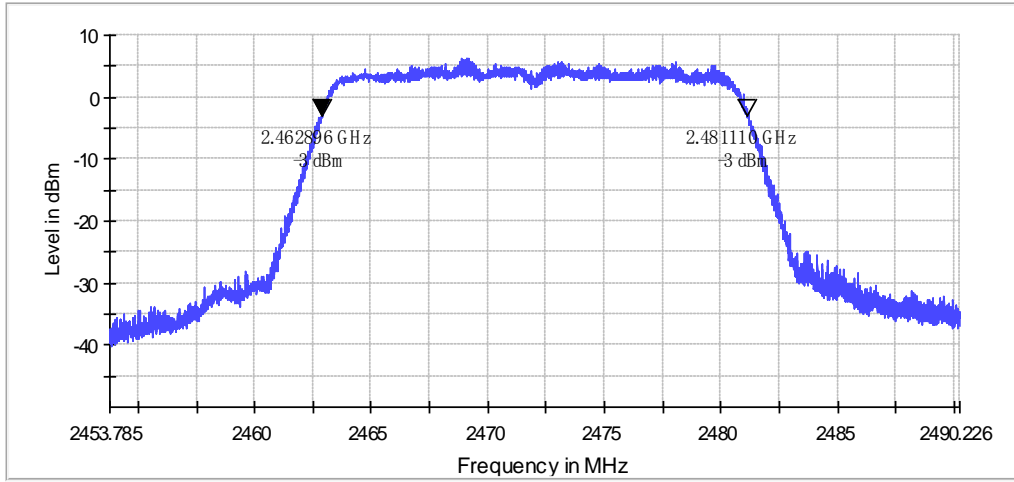

Plot F

802.11n40: RBW=1MHz VBW=3MHz Span(refer to plot)

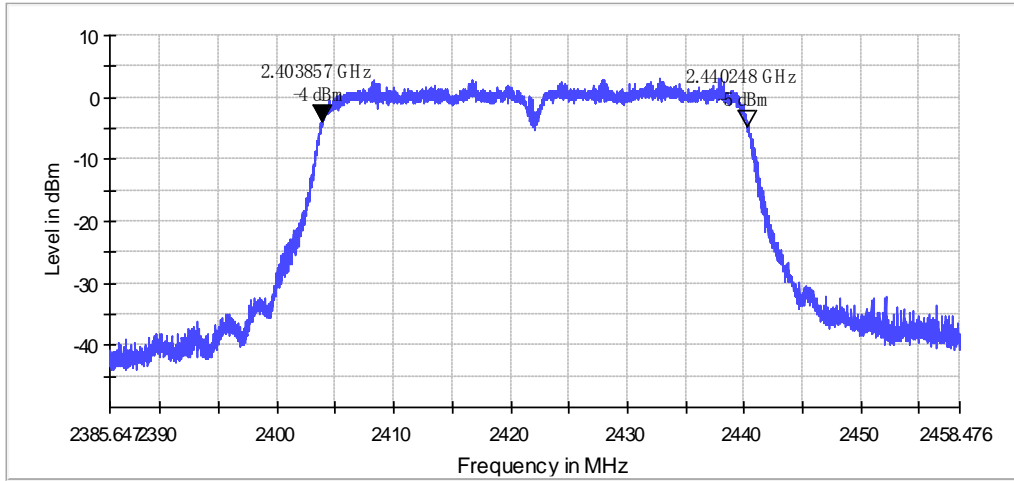

Plot G

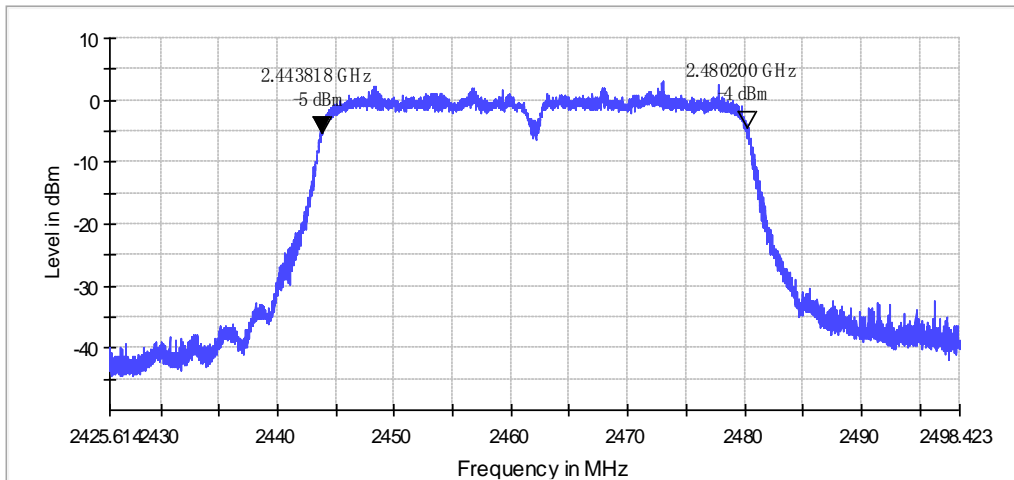

Plot H



| | |
|--------------|-------------|
| Temperature: | 20°C |
| Voltage: | 5V |
| Mode No.: | GWF-3M08-5V |

| Test Condition | Temperature 20 °C, Voltage 5V | | | | |
|------------------|-------------------------------|----------------------------------|-----------------------|-----------------------|---------------|
| Mode and channel | Channel center Frequency(MHz) | Occupied Channel Bandwidth (MHz) | Lower Band Edge (MHz) | Upper Band Edge (MHz) | Refer to plot |
| 802.11 b(1ch) | 2412.013739 | 15.151735 | 2404.437871 | 2419.589606 | Plot A1 |
| 802.11 b(13ch) | 2471.990282 | 15.144242 | 2464.418161 | 2479.562403 | Plot B1 |
| 802.11 g(1ch) | 2411.991580 | 17.375328 | 2403.303916 | 2420.679244 | Plot C1 |
| 802.11 g(13ch) | 2471.972645 | 17.390319 | 2463.277485 | 2480.667804 | Plot D1 |
| 802.11 n20(1ch) | 2412.025646 | 18.227276 | 2402.912007 | 2421.139284 | Plot E1 |
| 802.11 n20(13ch) | 2472.001815 | 18.237718 | 2462.882956 | 2481.120674 | Plot F1 |
| 802.11 n40(3ch) | 2422.059424 | 36.410046 | 2403.854401 | 2440.264447 | Plot G1 |
| 802.11n40(11ch) | 2462.026475 | 36.410046 | 2443.821452 | 2480.231498 | Plot H1 |
| Test Verdict | PASS | | | | |

802.11b: RBW=300kHz VBW=1MHz Span(refer to plot)

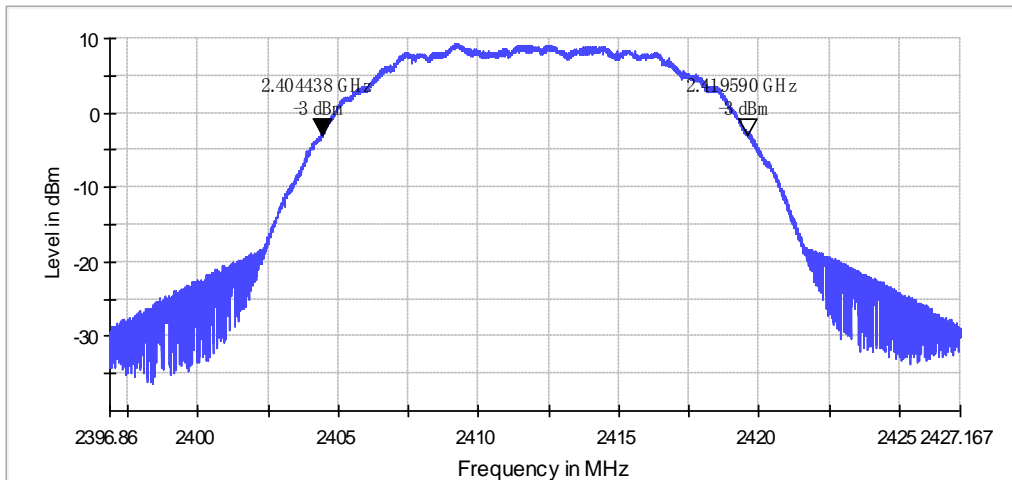

Plot A1

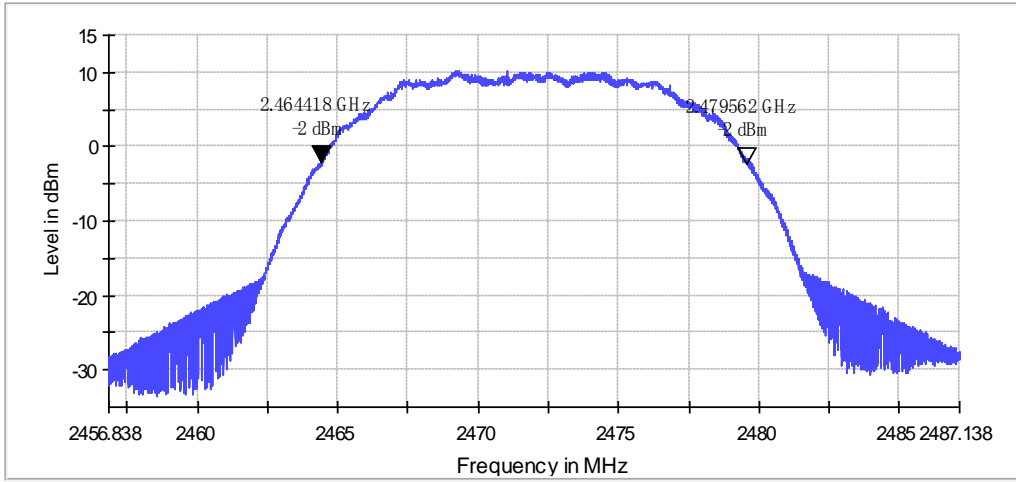

Plot B1

802.11g: RBW=1MHz VBW=3MHz Span(refer to plot)

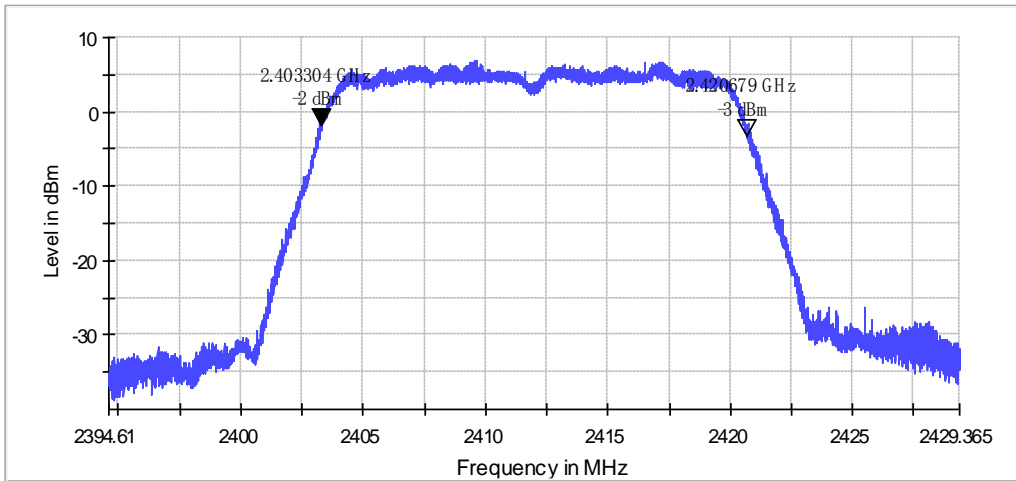

Plot C1

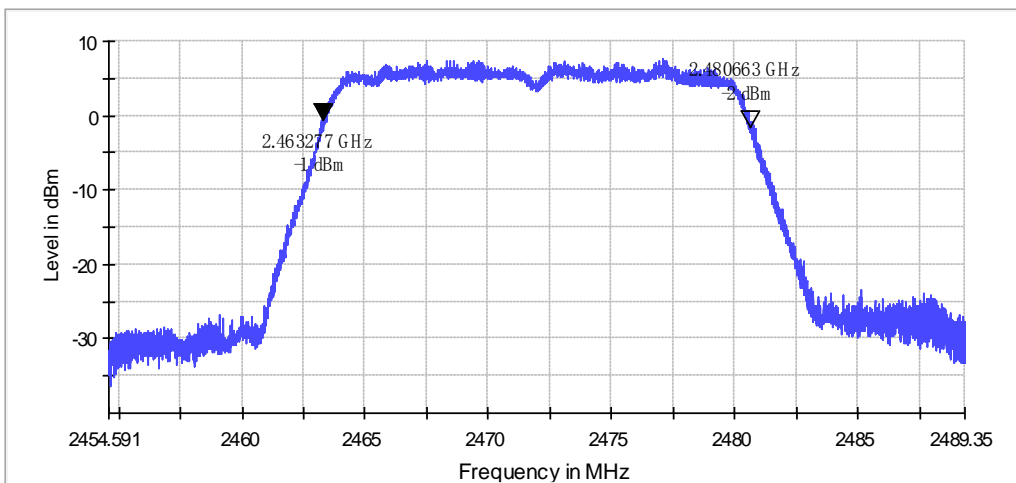

Plot D1



802.11n20: RBW=1MHz VBW=3MHz Span(refer to plot)

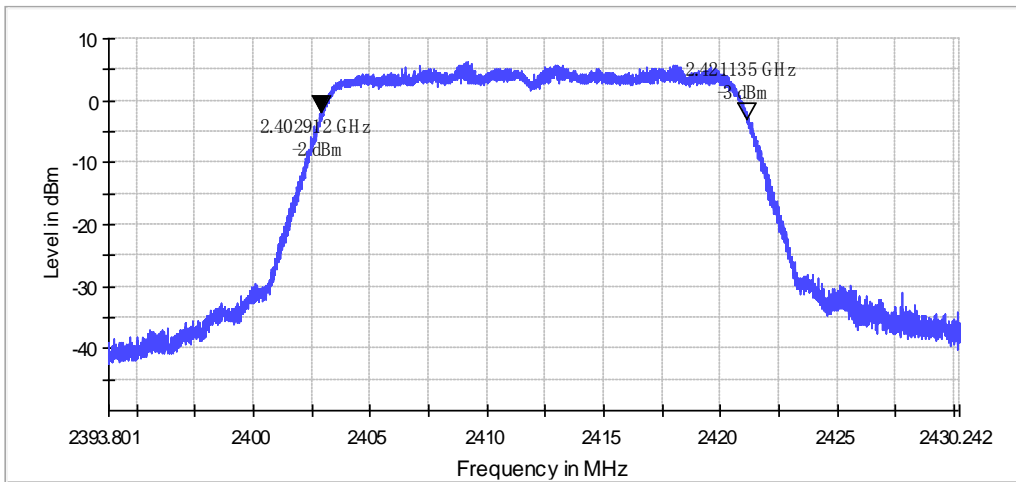

Plot E1

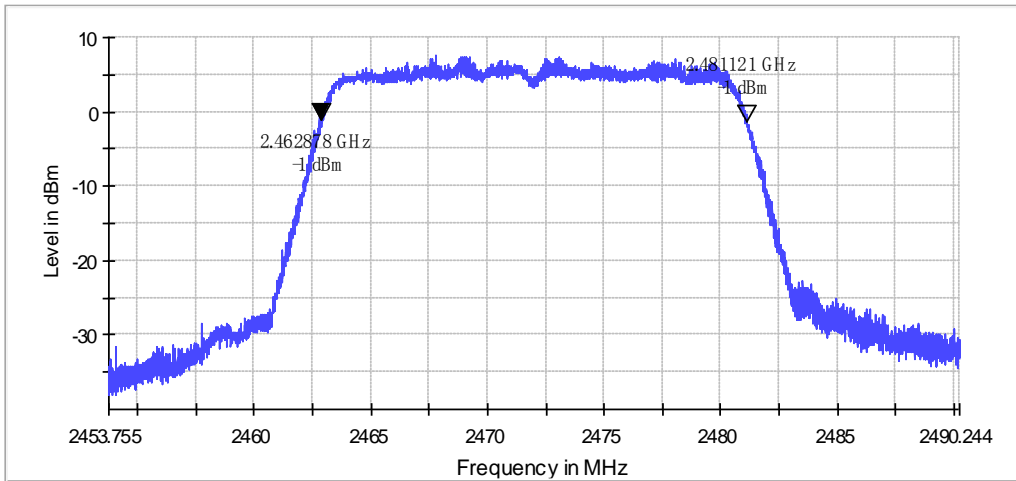

Plot F1

802.11n40: RBW=1MHz VBW=3MHz Span(refer to plot)

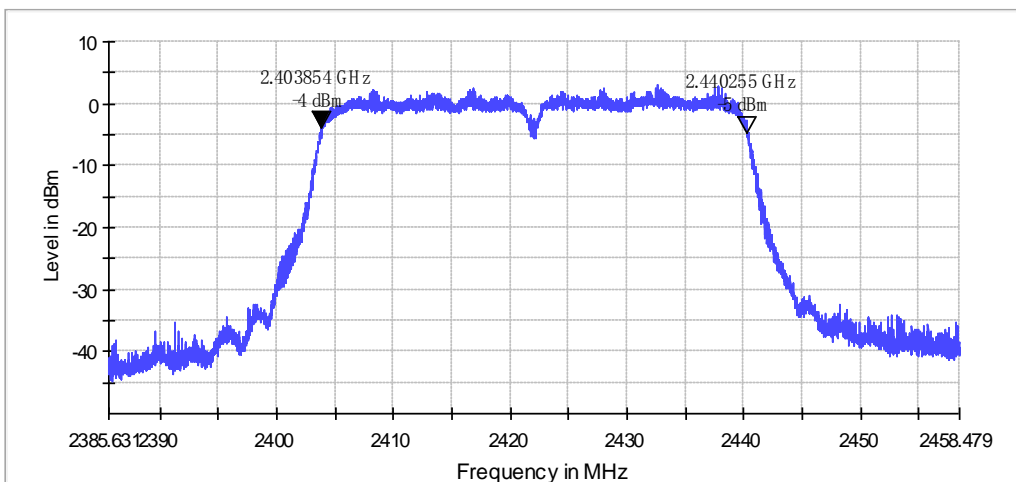

Plot G1

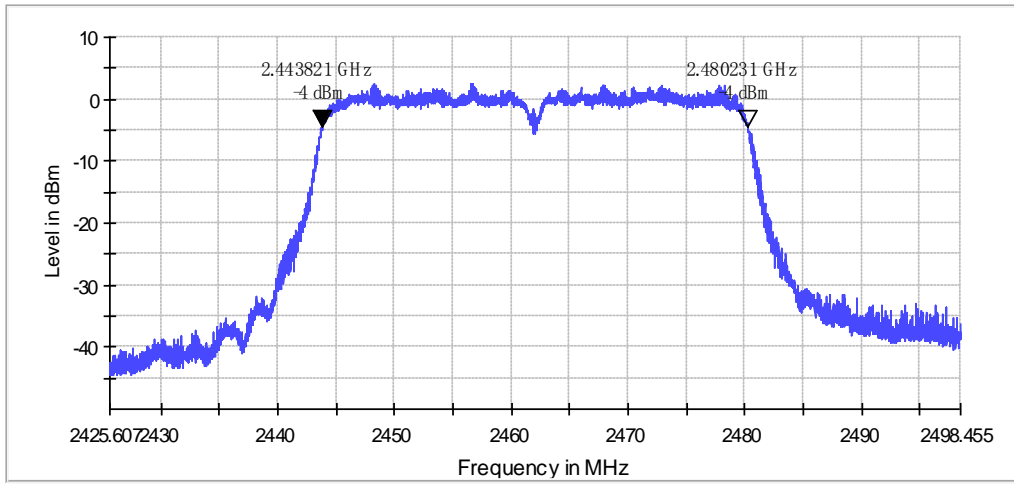

Plot H1



2.5. EN 300 328 §4.3.2.7 - Transmitter unwanted emissions in the out-of-band domain

Transmitter unwanted emissions in the out-of-band domain are emissions when the equipment is in Transmit mode, on frequencies immediately outside the necessary bandwidth which results from the modulation process, but excluding spurious.

2.5.1. Test Limit

The transmitter unwanted emissions in the out-of-band domain but outside the allocated band, shall not exceed the values provided by the mask in figure 1.

NOTE: Within the 2 400 MHz to 2 483,5 MHz band, the Out-of-band emissions are fulfilled by compliance with the Occupied Channel Bandwidth requirement in §2.4 in this report.

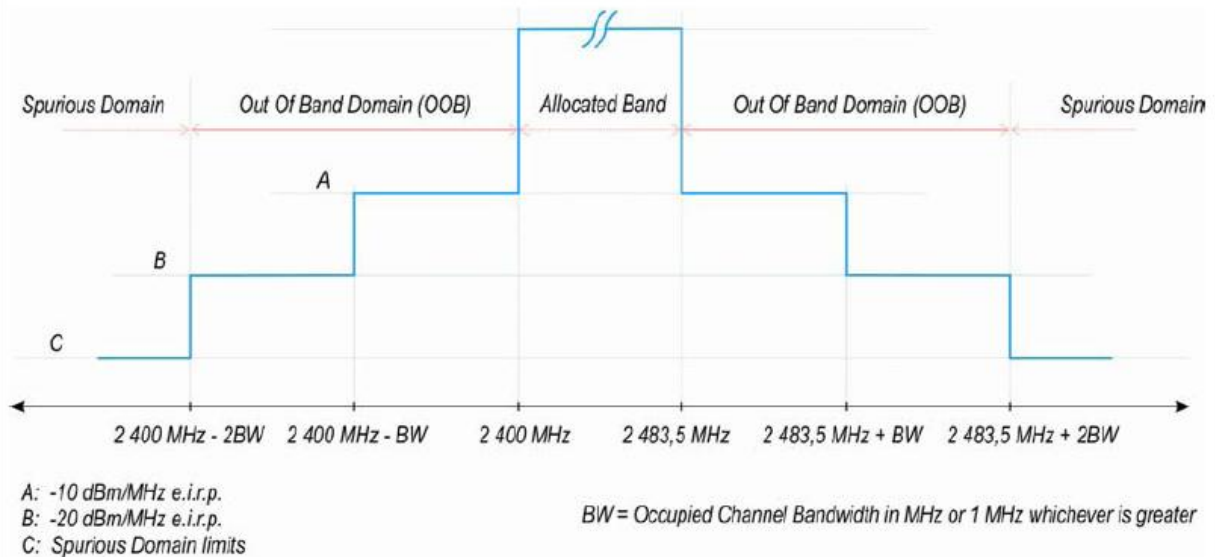

2.5.2. Test Configuration

Please refer to 2.2.2

2.5.3. Test Procedure

Please refer to ETSI EN 300 328 (V1.8.1) Sub-clause 5.3.9 for the measurement method. The conducted measurement method was used in this report.

For systems using wide band modulations other than FHSS, the measurement shall be performed at the lowest and the highest channel on which the equipment can operate. These frequencies shall be recorded.

The equipment shall be configured to operate under its worst case situation with respect to output power.

If the equipment can operate with different Occupied Channel Bandwidths (e.g. 20 MHz and 40 MHz), than each channel bandwidth shall be tested separately.

The Out-of-band emissions within the different horizontal segments of the mask provided in

figures 1 and 3 shall be measured using the steps below. This method assumes the spectrum analyser is equipped with the Time Domain Power option.

Step 1:

- Connect the UUT to the spectrum analyser and use the following settings:
 - Centre Frequency: 2 484 MHz
 - Span: 0 Hz
 - Resolution BW: 1 MHz
 - Filter mode: Channel filter
 - Video BW: 3 MHz
 - Detector Mode: RMS
 - Trace Mode: Clear / Write
 - Sweep Mode: Continuous
 - Sweep Points: 5 000
 - Trigger Mode: Video trigger

NOTE 1: In case video triggering is not possible, an external trigger source may be used.

- Sweep Time: Suitable to capture one transmission burst

Step 2: (segment 2 483,5 MHz to 2 483,5 MHz + BW)

- Adjust the trigger level to select the transmissions with the highest power level.
- For frequency hopping equipment operating in a normal hopping mode, the different hops will result in signal bursts with different power levels. In this case the burst with the highest power level shall be selected.
 - Set a window (start and stop lines) to match with the start and end of the burst and in which the RMS power shall be measured using the Time Domain Power function.
 - Select RMS power to be measured within the selected window and note the result which is the RMS power within this 1 MHz segment (2 483,5 MHz to 2 484,5 MHz). Compare this value with the applicable limit provided by the mask.
 - Increase the centre frequency in steps of 1 MHz and repeat this measurement for every 1 MHz segment within the range 2 483,5 MHz to 2 483,5 MHz + BW. The centre frequency of the last 1 MHz segment shall be set to 2 483,5 MHz + BW - 0,5 MHz (which means this may partly overlap with the previous 1 MHz segment).

Step 3: (segment 2 483,5 MHz + BW to 2 483,5 MHz + 2BW)

- Change the centre frequency of the analyser to 2 484 MHz + BW and perform the measurement for the first 1 MHz segment within range 2 483,5 MHz + BW to 2 483,5 MHz + 2BW. Increase the centre frequency in 1 MHz steps and repeat the measurements to cover this whole range. The centre frequency of the last 1 MHz segment shall be set to 2 483,5 MHz + 2 BW - 0,5 MHz.

Step 4: (segment 2 400 MHz - BW to 2 400 MHz)

- Change the centre frequency of the analyser to 2 399,5 MHz and perform the measurement for the first 1 MHz segment within range 2 400 MHz - BW to 2 400 MHz Reduce the centre frequency in 1 MHz steps and repeat the measurements to cover this whole range. The centre frequency of the last 1 MHz segment shall be set to 2 400 MHz - 2BW + 0,5 MHz.

Step 5: (segment 2 400 MHz - 2BW to 2 400 MHz - BW)

- Change the centre frequency of the analyser to 2 399,5 MHz - BW and perform the measurement for the first 1 MHz segment within range 2 400 MHz - 2BW to 2 400 MHz - BW. Reduce the centre frequency in 1 MHz steps and repeat the measurements to cover this whole range.

The centre frequency of the last 1 MHz segment shall be set to $2\,400\text{ MHz} - 2\text{BW} + 0,5\text{ MHz}$.

Step 6:

- In case of conducted measurements on equipment with a single transmit chain, the declared antenna assembly gain "G" in dBi shall be added to the results for each of the 1 MHz segments and compared with the limits provided by the mask given in figures 1 or 3. If more than one antenna assembly is intended for this power setting, the antenna with the highest gain shall be considered.
 - In case of conducted measurements on smart antenna systems (equipment with multiple transmit chains), the measurements need to be repeated for each of the active transmit chains. The declared antenna assembly gain "G" in dBi for a single antenna shall be added to these results. If more than one antenna assembly is intended for this power setting, the antenna with the highest gain shall be considered. Comparison with the applicable limits shall be done using any of the options given below:
 - Option 1: the results for each of the transmit chains for the corresponding 1 MHz segments shall be added. The additional beamforming gain "Y" in dB shall be added as well and the resulting values compared with the limits provided by the mask given in figures 1 or 3.
 - Option 2: the limits provided by the mask given in figures 1 or 3 shall be reduced by $10 \times \log_{10}(\text{Ach})$ and the additional beamforming gain "Y" in dB. The results for each of the transmit chains shall be individually compared with these reduced limits.
- NOTE 2: Ach refers to the number of active transmit chains.
- It shall be recorded whether the equipment complies with the mask provided in figures 1 or 3.

2.5.4. Test Results:

| | |
|-----------|---------------|
| Mode No.: | GWF-3M08-3.3V |
| RBW: | 1MHz |
| VBW: | 3MHz |
| Span: | 0Hz |

| Test conditions | | Mode | Channel | | Result |
|-----------------|-------|-----------|----------|-----------|--------|
| | | | Low | High | |
| 20°C | 3.3V | 802.11b | 1channel | 13channel | PASS |
| | | 802.11g | 1channel | 13channel | PASS |
| | | 802.11n20 | 1channel | 13channel | PASS |
| | | 802.11n40 | 3channel | 11channel | PASS |
| -20°C | 3.45V | 802.11b | 1channel | 13channel | PASS |
| | | 802.11g | 1channel | 13channel | PASS |
| | | 802.11n20 | 1channel | 13channel | PASS |
| | | 802.11n40 | 3channel | 11channel | PASS |
| -20°C | 3.15V | 802.11b | 1channel | 13channel | PASS |
| | | 802.11g | 1channel | 13channel | PASS |
| | | 802.11n20 | 1channel | 13channel | PASS |
| | | 802.11n40 | 3channel | 11channel | PASS |
| 55°C | 3.45V | 802.11b | 1channel | 13channel | PASS |
| | | 802.11g | 1channel | 13channel | PASS |

| | | | | | |
|------|-------|-----------|----------|-----------|------|
| 55°C | 3.15V | 802.11n20 | 1channel | 13channel | PASS |
| | | 802.11n40 | 3channel | 11channel | PASS |
| | | 802.11b | 1channel | 13channel | PASS |
| | | 802.11g | 1channel | 13channel | PASS |
| | | 802.11n20 | 1channel | 13channel | PASS |
| | | 802.11n40 | 3channel | 11channel | PASS |

Note: The attached plots are worst results.

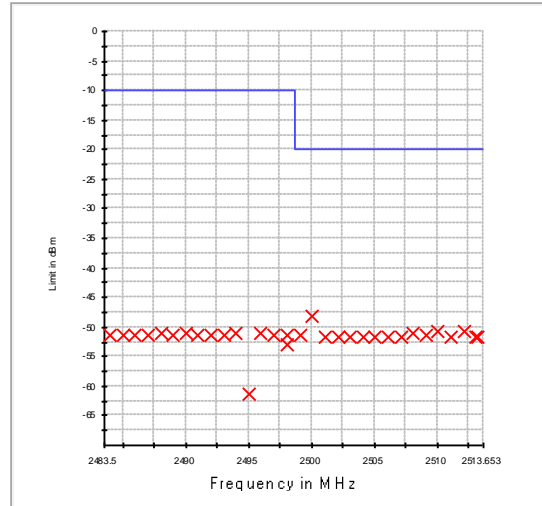
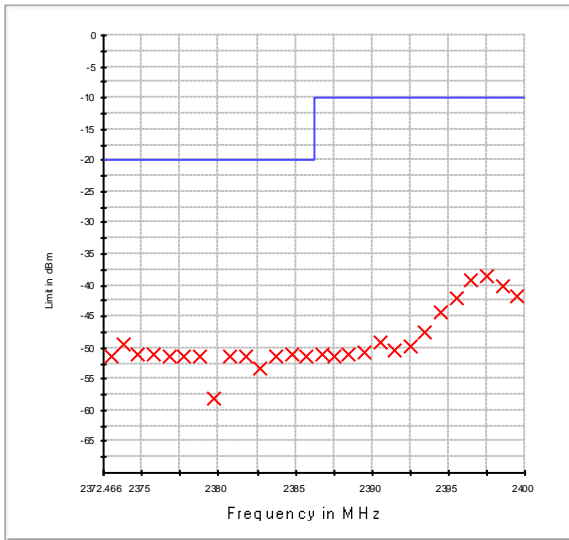

802.11b mode @ 1 channel 55°C 3.45V

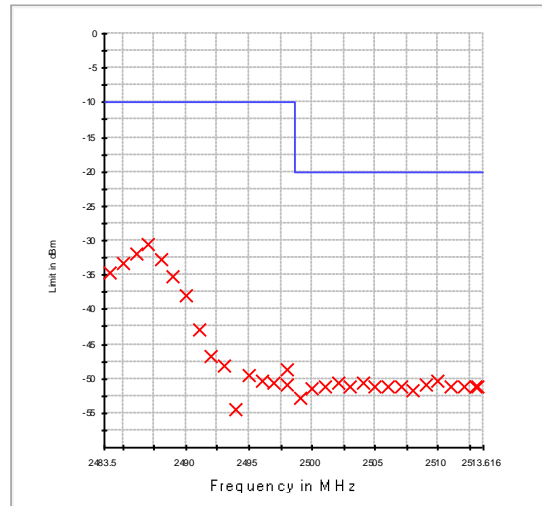
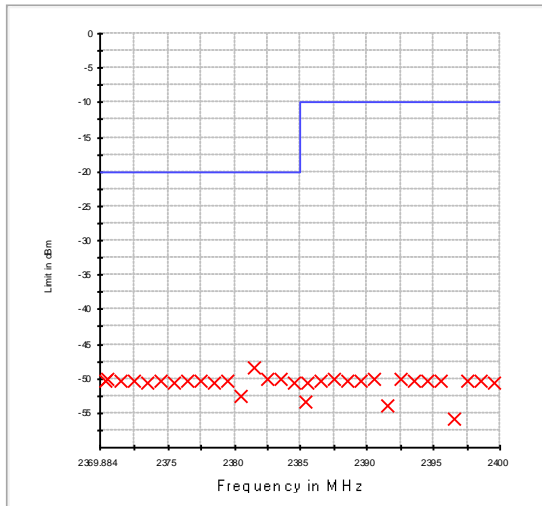

802.11b mode @ 13 channel 55°C 3.45V

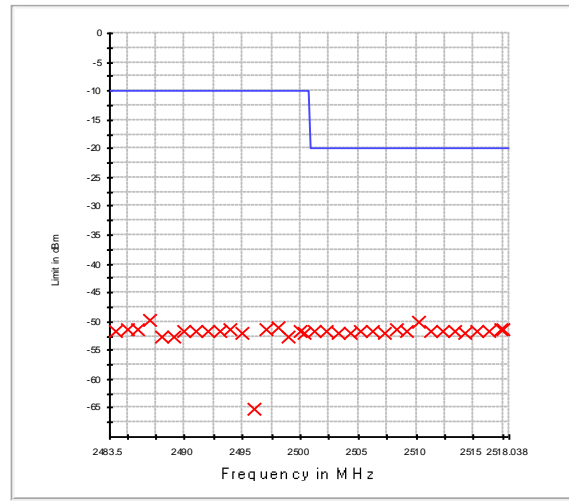
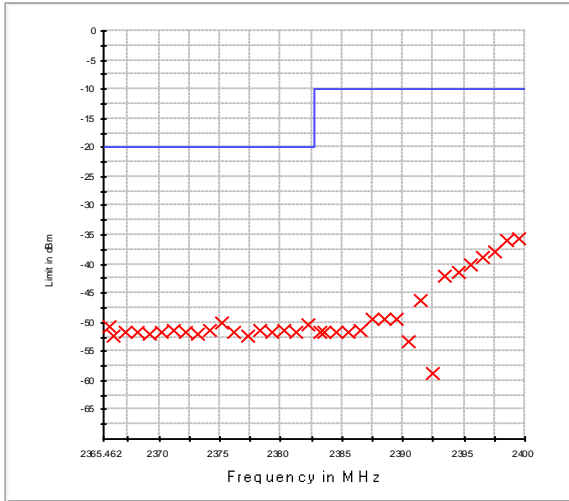

802.11g mode @ 1 channel 55°C 3.45V

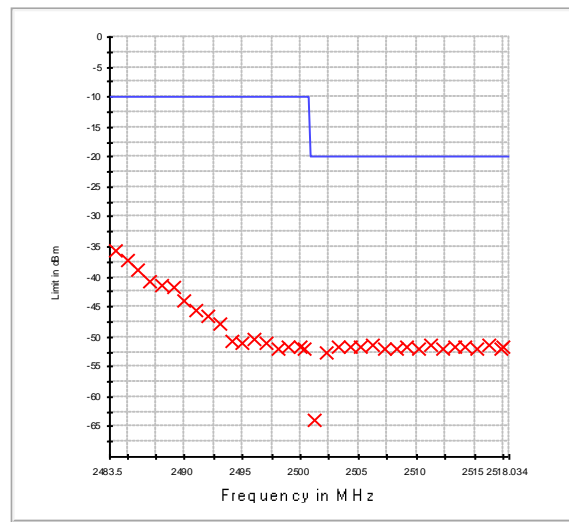
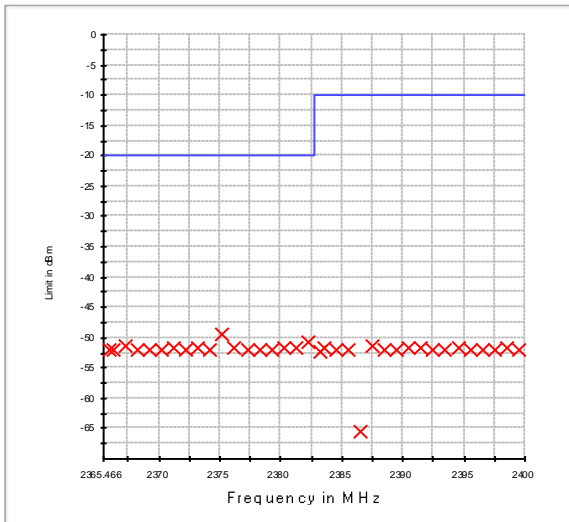

802.11g mode @ 13 channel 55°C 3.45V

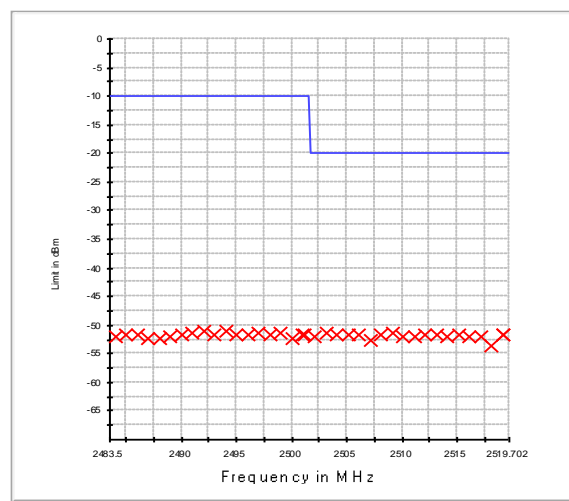
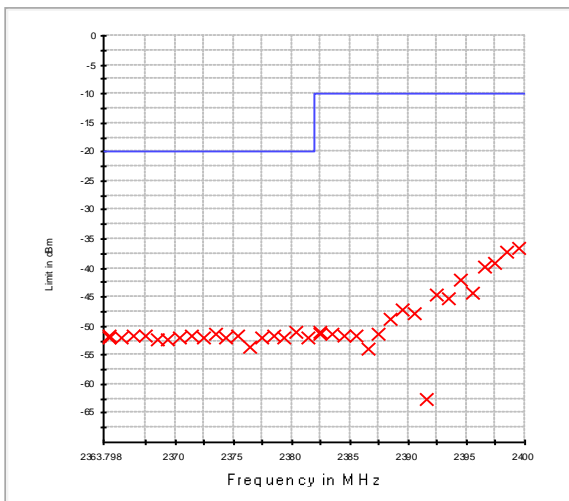

802.11n20 mode @ 1 channel 55°C 3.45V



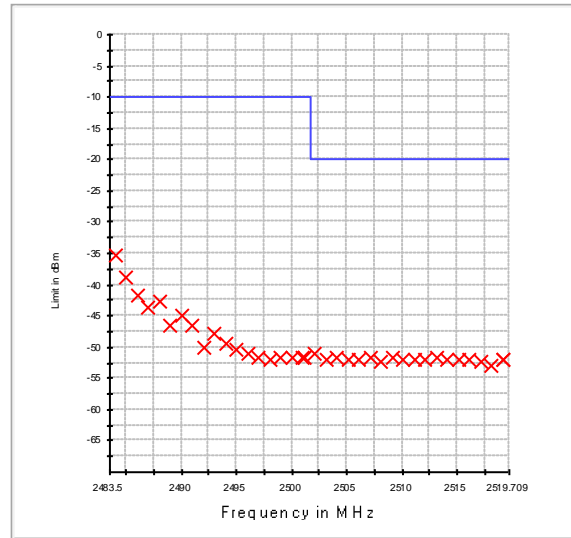
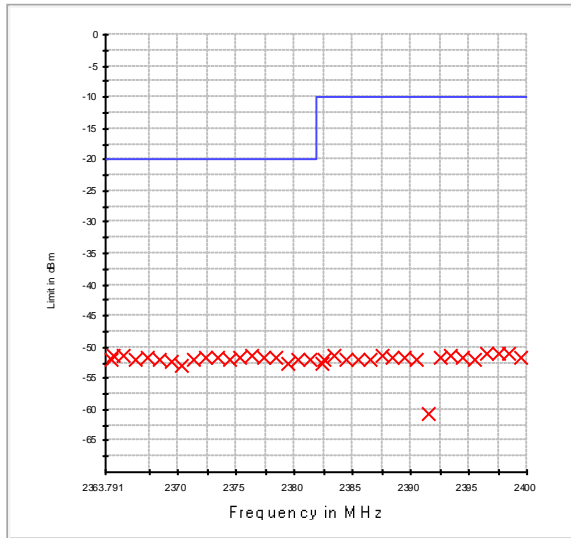

802.11n20 mode @ 13 channel 55°C 3.45V

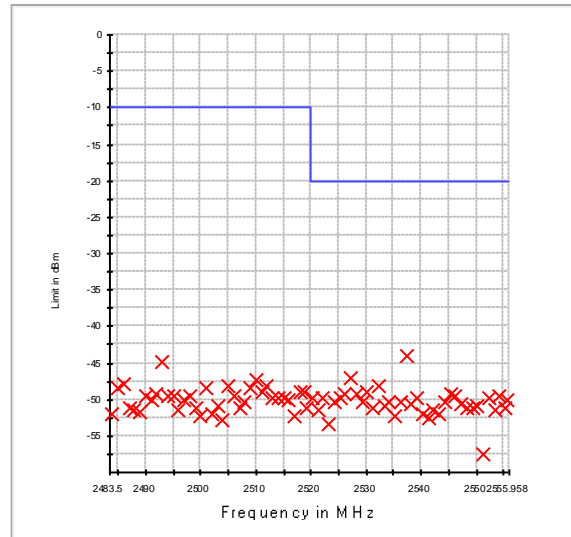
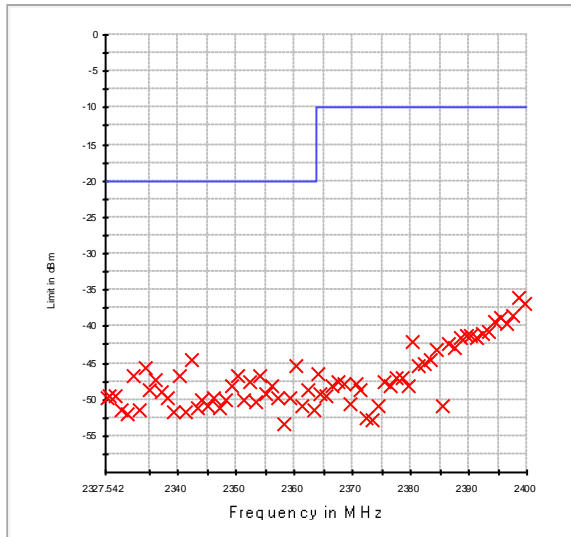

802.11n40 mode @ 3 channel 55°C 3.45V

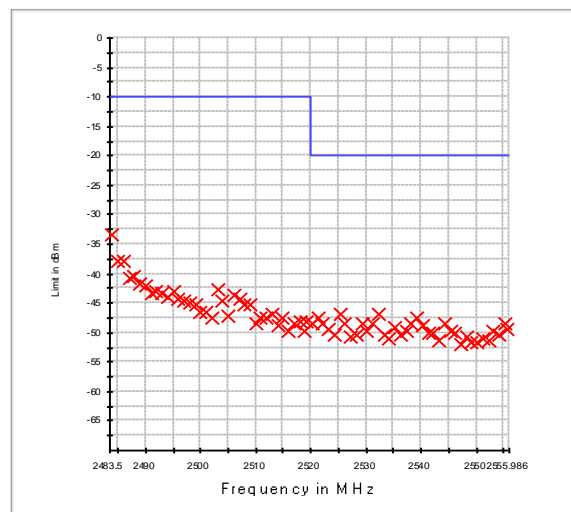
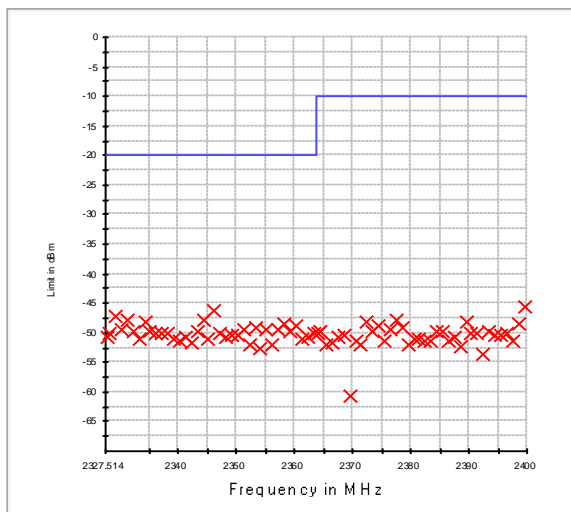

802.11n40 mode @ 11 channel 55°C 3.45V





| | |
|-----------|-------------|
| Mode No.: | GWF-3M08-5V |
| RBW: | 1MHz |
| VBW: | 3MHz |
| Span: | 0Hz |

| Test conditions | | Mode | Channel | | Result |
|-----------------|-------|-----------|----------|-----------|--------|
| | | | Low | High | |
| 20°C | 5V | 802.11b | 1channel | 13channel | PASS |
| | | 802.11g | 1channel | 13channel | PASS |
| | | 802.11n20 | 1channel | 13channel | PASS |
| | | 802.11n40 | 3channel | 11channel | PASS |
| -20°C | 5.25V | 802.11b | 1channel | 13channel | PASS |
| | | 802.11g | 1channel | 13channel | PASS |
| | | 802.11n20 | 1channel | 13channel | PASS |
| | | 802.11n40 | 3channel | 11channel | PASS |
| -20°C | 4.75V | 802.11b | 1channel | 13channel | PASS |
| | | 802.11g | 1channel | 13channel | PASS |
| | | 802.11n20 | 1channel | 13channel | PASS |
| | | 802.11n40 | 3channel | 11channel | PASS |
| 55°C | 5.25V | 802.11b | 1channel | 13channel | PASS |
| | | 802.11g | 1channel | 13channel | PASS |
| | | 802.11n20 | 1channel | 13channel | PASS |
| | | 802.11n40 | 3channel | 11channel | PASS |
| 55°C | 4.75V | 802.11b | 1channel | 13channel | PASS |
| | | 802.11g | 1channel | 13channel | PASS |
| | | 802.11n20 | 1channel | 13channel | PASS |
| | | 802.11n40 | 3channel | 11channel | PASS |

Note: The attached plots are worst results.

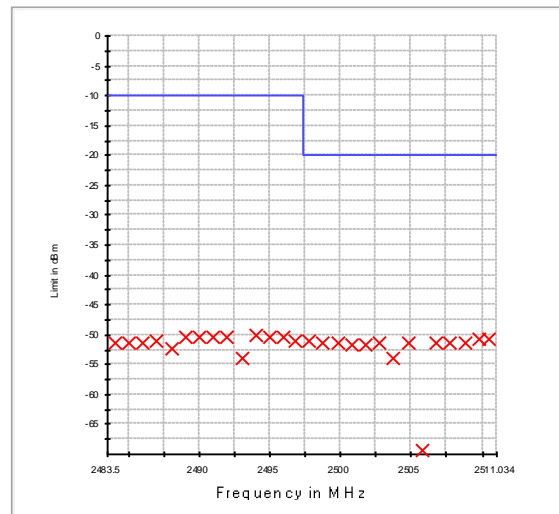
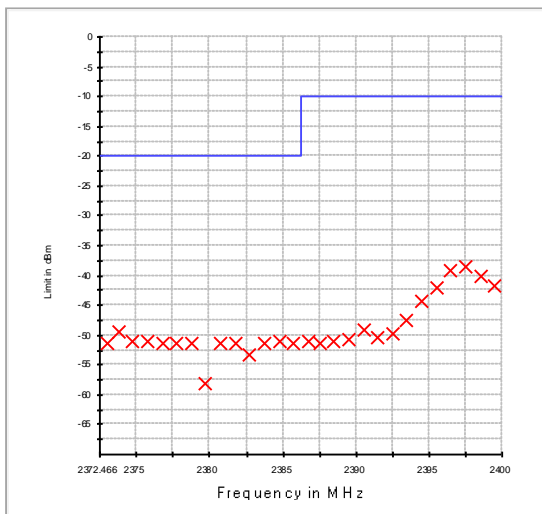

802.11b mode @ 1 channel 55°C 5.25V

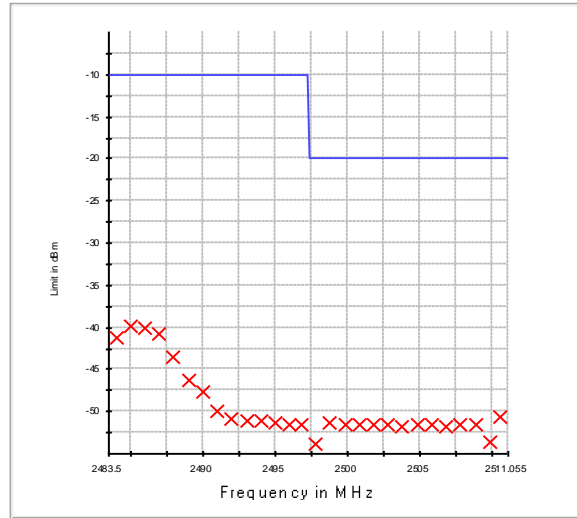
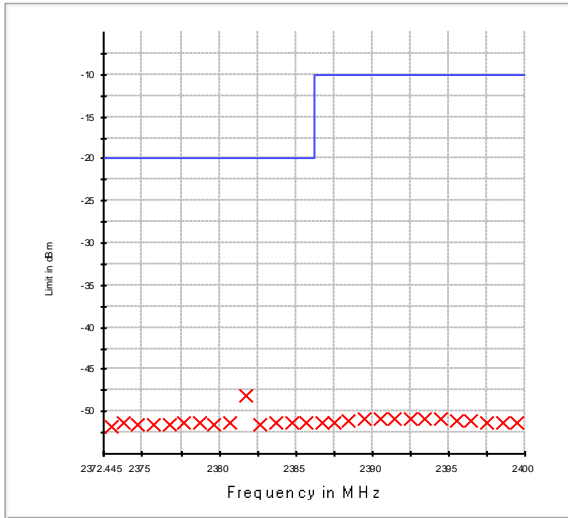

802.11b mode @ 13 channel 55°C 5.25V

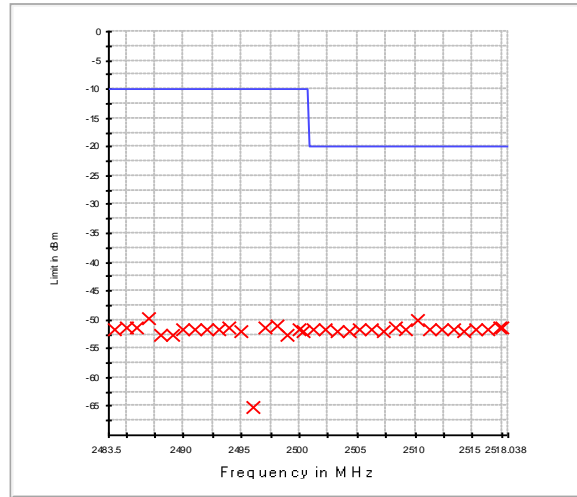
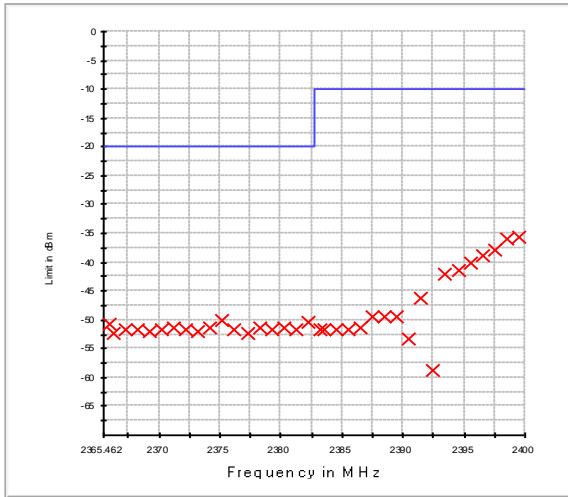

802.11g mode @ 1 channel 55°C 5.25V

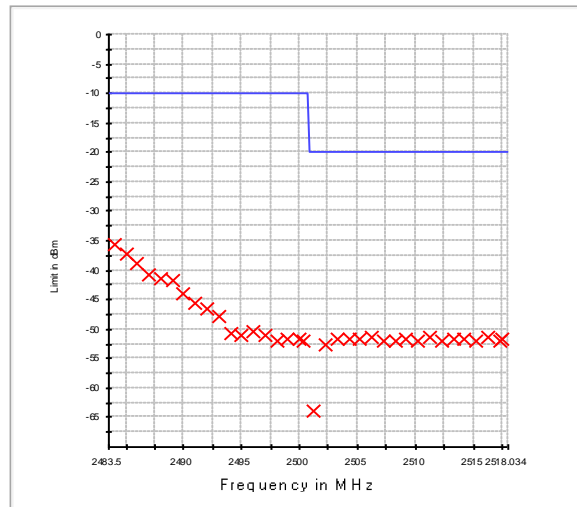
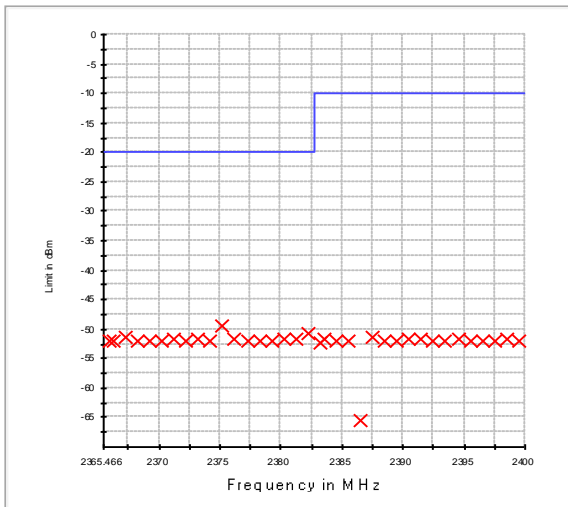

802.11g mode @ 13 channel 55°C 5.25V

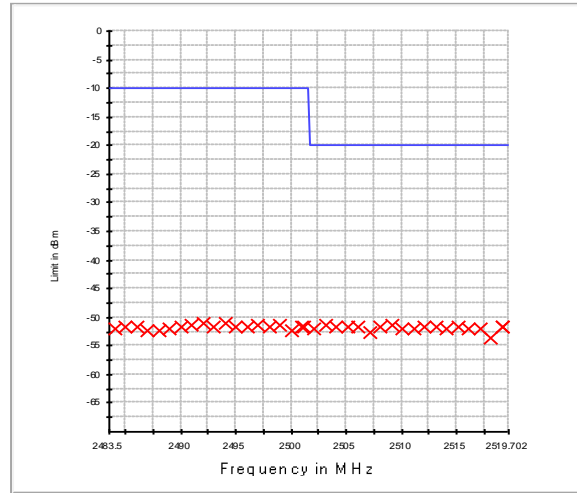
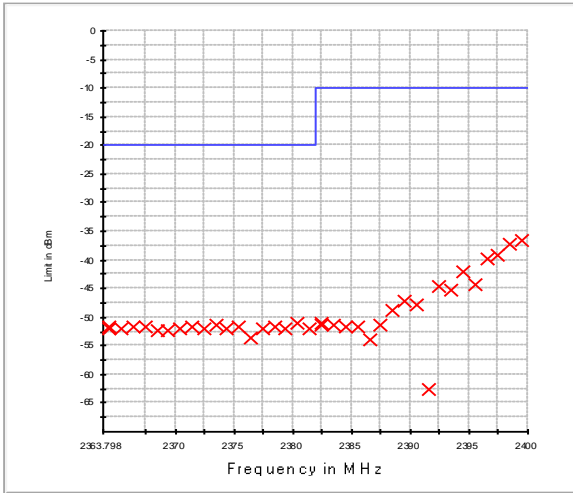

802.11n20 mode @ 1 channel 55°C 5.25V

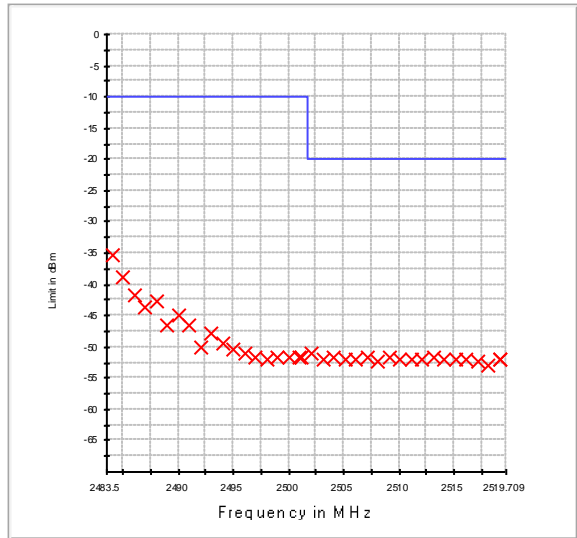
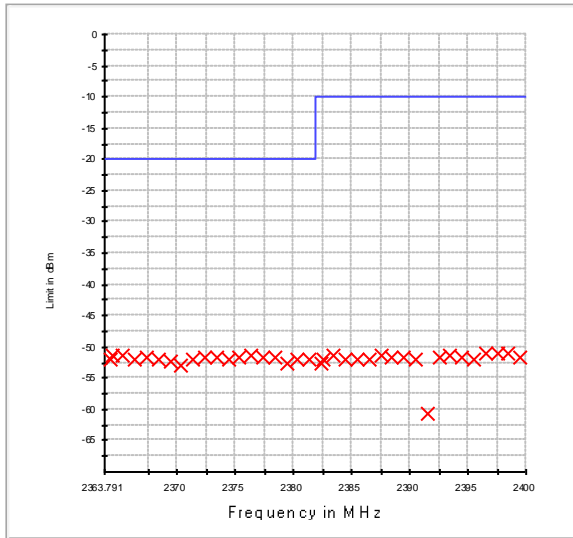

802.11n20 mode @ 13 channel 55°C 5.25V

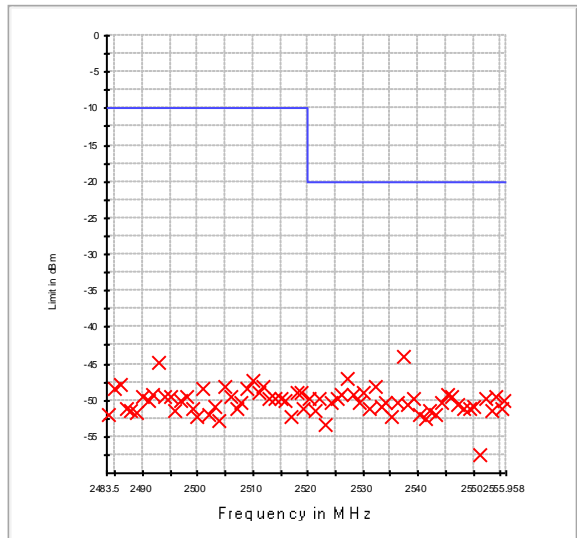
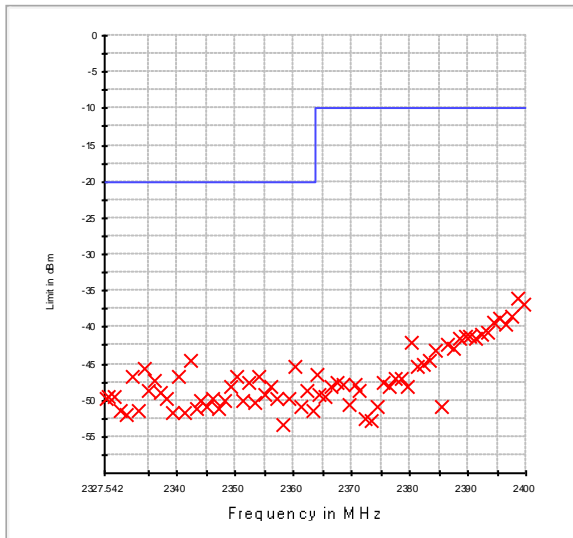

802.11n40 mode @ 3 channel 55°C 5.25V



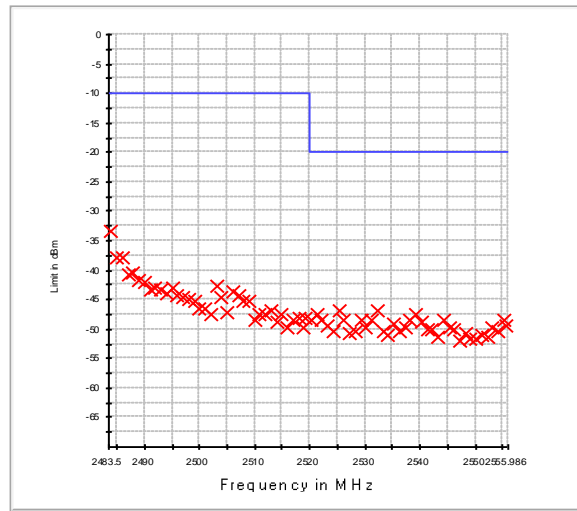
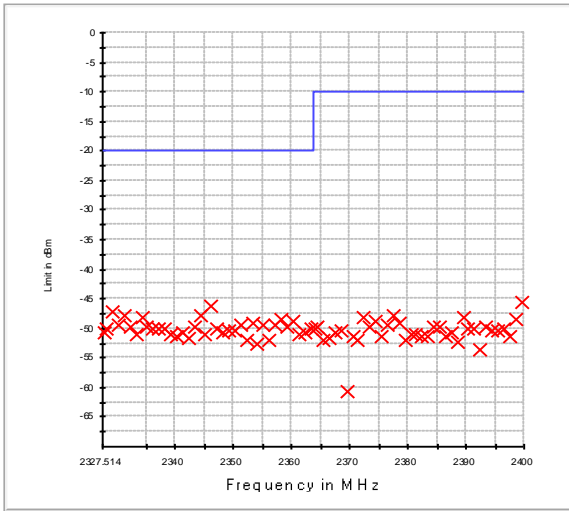

802.11n40 mode@ 11 channel 55°C 5.25V



2.6. EN 300 328 §4.3.2.8 - Transmitter unwanted emissions in the spurious domain

Transmitter unwanted emissions in the spurious domain are emissions outside the allocated band and outside the out-of-band domain as indicated in figure 1 when the equipment is in Transmit mode.

2.6.1. Test Limit

| Frequency range | Maximum power, e.r.p. (≤ 1 GHz) e.i.r.p. (> 1 GHz) (dBm) | Bandwidth |
|-------------------|--|-----------|
| 30MHz to 47MHz | -36 | 100kHz |
| 47MHz to 74MHz | -54 | 100kHz |
| 74MHz to 87.5MHz | -36 | 100kHz |
| 87.5MHz to 118MHz | -54 | 100kHz |
| 118MHz to 174MHz | -36 | 100kHz |
| 174MHz to 230MHz | -54 | 100kHz |
| 230MHz to 470MHz | -36 | 100kHz |
| 470MHz to 862MHz | -54 | 100kHz |
| 862MHz to 1GHz | -36 | 100kHz |
| 1GHz to 12.75GHz | -30 | 1MHz |

2.6.2. Test Configuration

Please refer to 2.2.2

2.6.3. Test Procedure

Please refer to ETSI EN 300 328 (V1.8.1) Sub-clause 5.3.10 for the measurement method.

The conducted measurement method was used in this report.

In case of conducted measurements, the radio equipment shall be connected to the measuring equipment via a suitable attenuator. The spectrum in the spurious domain (see figures 1 or 3) shall be searched for emissions that exceed the limit values given in tables 1 or 4 or that come to within 6 dB below these limits. Each occurrence shall be recorded.

The measurement procedure shall be as follows.

Pre-scan

The test procedure below shall be used to identify potential unwanted emissions of the UUT.

Step 1:

The sensitivity of the spectrum analyser should be such that the noise floor is at least 12 dB below the limits given in tables 1 or 4.

Step 2:

The emissions over the range 30 MHz to 1 000 MHz shall be identified.

Spectrum analyser settings:

- Resolution bandwidth: 100 kHz
- Video bandwidth: 300 kHz
- Detector mode: Peak
- Trace Mode: Max Hold
- Sweep Points: $\geq 9\,970$

NOTE 1: For spectrum analysers not supporting this high number of sweep points, the frequency band may need to be segmented.

• Sweep time: For non continuous transmissions (duty cycle less than 100 %), the sweep time shall be sufficiently long, such that for each 100 kHz frequency step, the measurement time is greater than two transmissions of the UUT. For Frequency Hopping equipment operating in a normal operating (hopping not disabled) mode, the sweep time shall be further increased to capture multiple transmissions on the same hopping frequency in different hopping sequences.

Allow the trace to stabilize. Any emissions identified during the sweeps above and that fall within the 6 dB range below the applicable limit or above, shall be individually measured using the procedure in clause 5.3.10.2.1.2 and compared to the limits given in tables 1 or 4.

Step 3:

The emissions over the range 1 GHz to 12,75 GHz shall be identified.

Spectrum analyser settings:

- Resolution bandwidth: 1 MHz
- Video bandwidth: 3 MHz
- Detector mode: Peak
- Trace Mode: Max Hold
- Sweep Points: $\geq 11\,750$

NOTE 2: For spectrum analysers not supporting this high number of sweep points, the frequency band may need to be segmented.

• Sweep time: For non continuous transmissions (duty cycle less than 100 %), the sweep time shall be sufficiently long, such that for each 1 MHz frequency step, the measurement time is greater than two transmissions of the UUT.

For Frequency Hopping equipment operating in a normal operating (hopping not disabled) mode, the sweep time shall be further increased to capture multiple transmissions on the same hopping frequency in different hopping sequences.

Allow the trace to stabilize. Any emissions identified during the sweeps above that fall within the 6 dB range below the applicable limit or above, shall be individually measured using the procedure in clause 5.3.10.2.1.2 and compared to the limits given in tables 1 or 4.

Frequency Hopping equipment may generate a block (or several blocks) of spurious emissions anywhere within the spurious domain. If this is the case, only the highest peak of each block of emissions shall be measured using the procedure in clause 5.3.10.2.1.2.

Step 4:

• In case of conducted measurements on smart antenna systems (equipment with multiple transmit chains), the steps 2 and 3 need to be repeated for each of the active transmit chains (Ach). The limits used to identify emissions during this pre-scan need to be reduced with $10 \times \log_{10}$ (Ach) (number of active transmit chains).

Measurement of the emissions identified during the pre-scan

The steps below shall be used to accurately measure the individual unwanted emissions identified during the pre-scan measurements above.

Step 1:

The level of the emissions shall be measured using the following spectrum analyser settings:

- Centre Frequency: Frequency of emission identified during the pre-scan
- Resolution Bandwidth: 100 kHz (< 1 GHz) / 1 MHz (> 1 GHz)
- Video Bandwidth: 300 kHz (< 1 GHz) / 3 MHz (> 1 GHz)
- Frequency Span: Wide enough to capture each individual emission identified during the

pre-scan

- Sweep mode: Continuous
- Sweep time: Auto
- Trigger: Free run
- Detector: RMS
- Trace Mode: Max Hold

Step 2:

In case of conducted measurements on smart antenna systems (equipment with multiple transmit chains), the step 1 needs to be repeated for each of the active transmit chains (Ach).

The trace data for each transmit chain has to be recorded.

Sum the power in each of the traces for each individual frequency bin.

Step 3:

Use the marker function to find the highest peak within the measurement trace and record its value and its frequency.

Step 4:

The measured values shall be compared to the limits defined in tables 1 and 4.

2.6.4. Test Results

| Mode No. | Mode | Low Channel | Refer to plot | High Channel | Refer to plot | Result |
|---------------|-----------|-------------|---------------|--------------|---------------|--------|
| GWF-3M08-3.3V | 802.11b | 1channel | Plot A | 13channel | Plot B | PASS |
| | 802.11g | 1channel | Plot C | 13channel | Plot D | PASS |
| | 802.11n20 | 1channel | Plot E | 13channel | Plot F | PASS |
| | 802.11n40 | 3channel | Plot G | 11channel | Plot H | PASS |

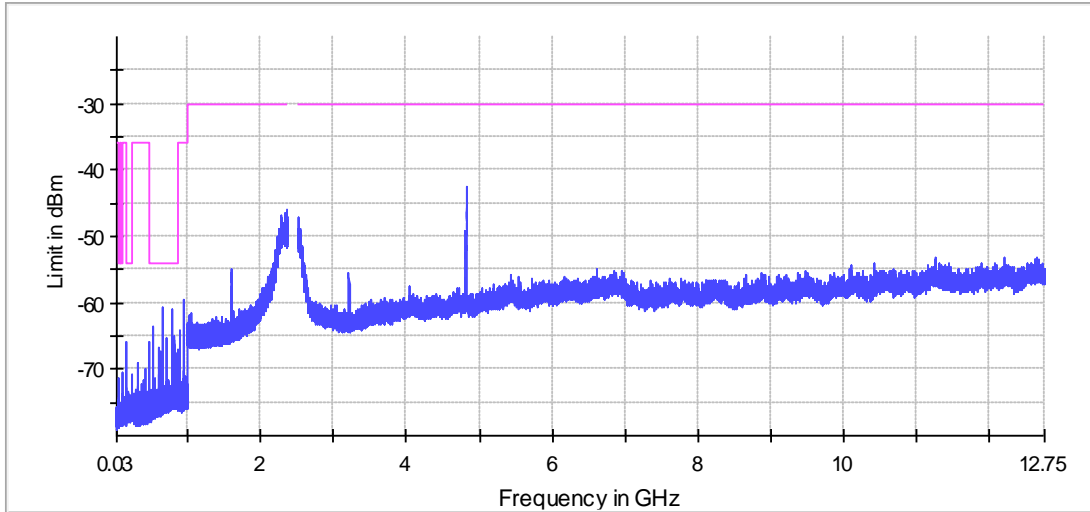

Plot A

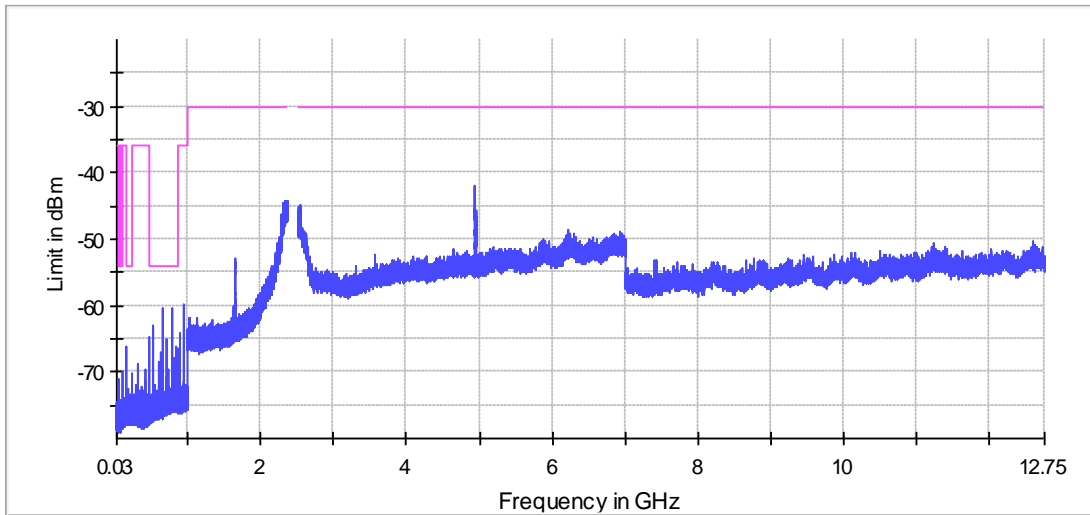

Plot B

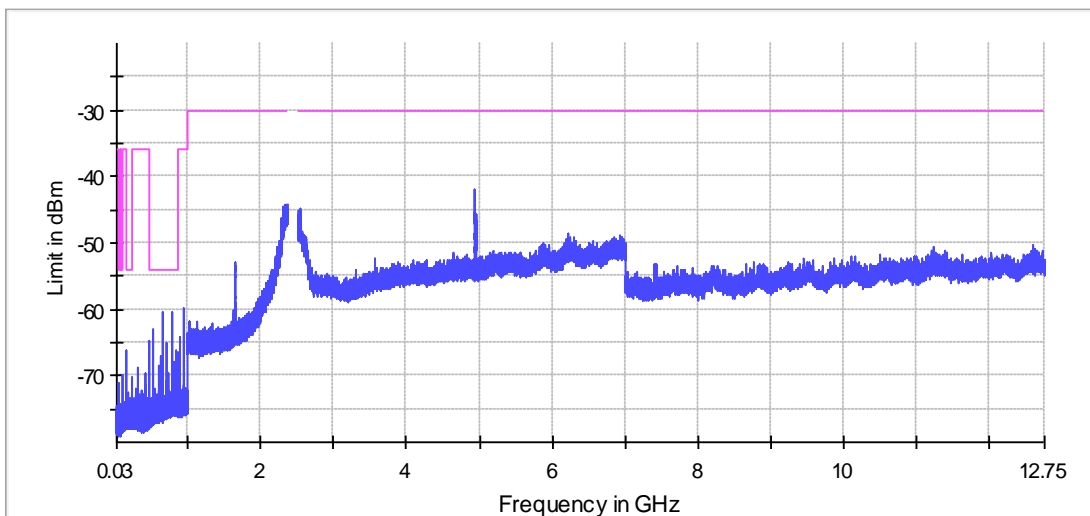

Plot C



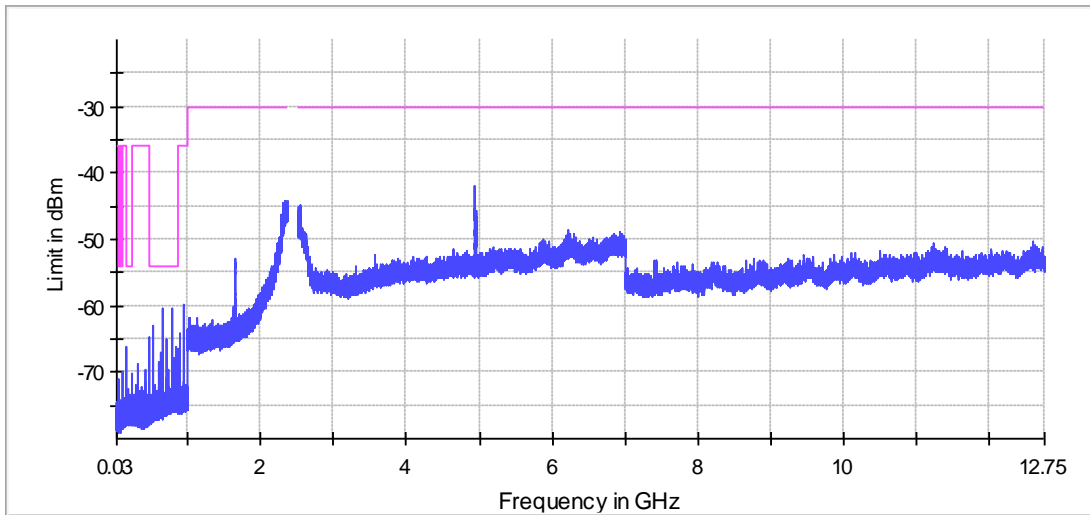

Plot D

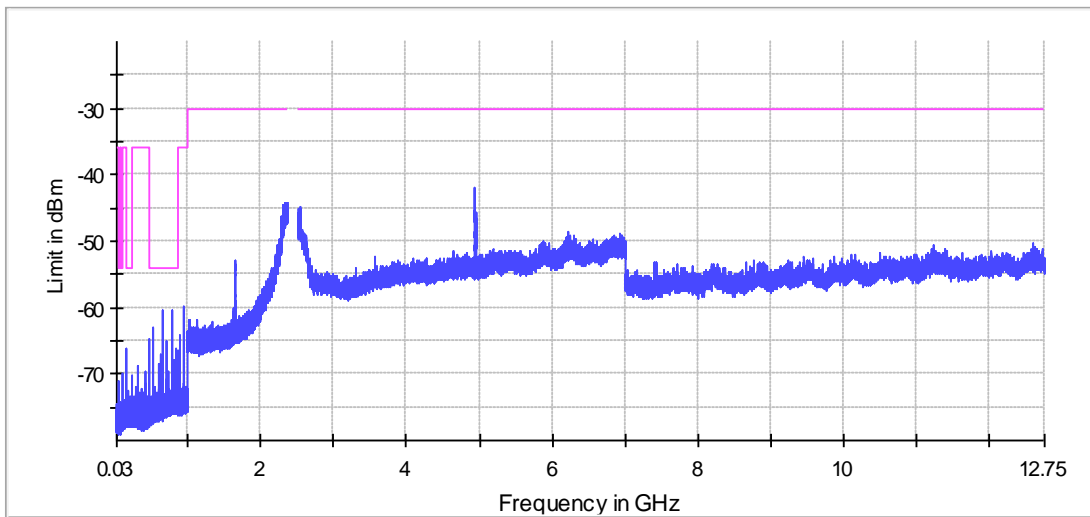

Plot E

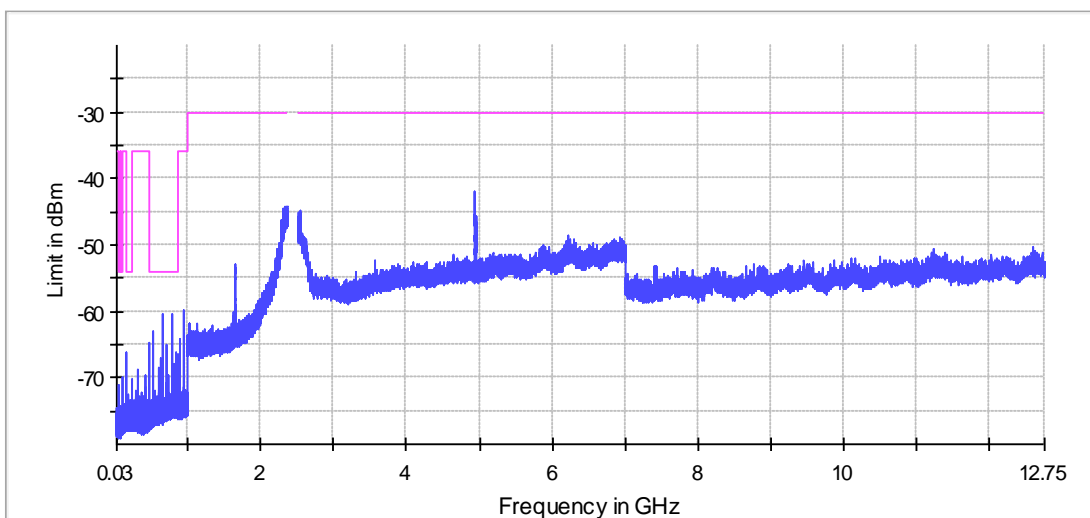

Plot F



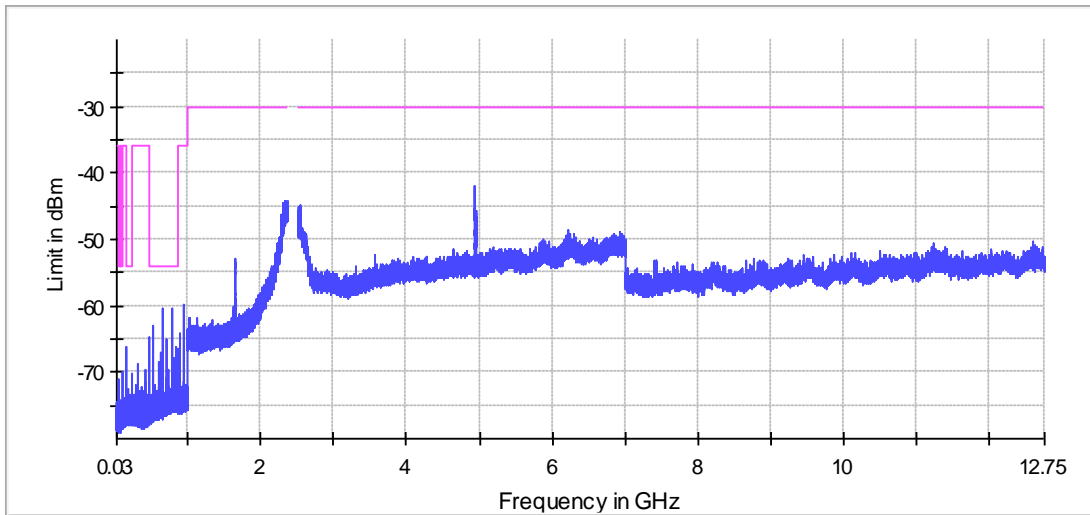

Plot G

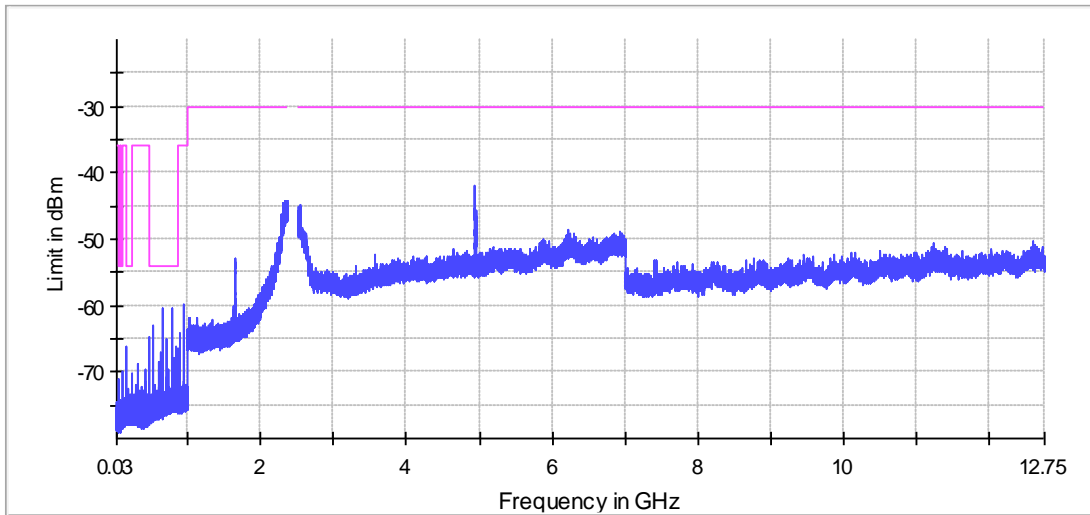

Plot H



| Mode No. | Mode | Low Channel | Refer to plot | High Channel | Refer to plot | Result |
|-------------|-----------|-------------|---------------|--------------|---------------|--------|
| GWF-3M08-5V | 802.11b | 1channel | Plot A1 | 13channel | Plot B1 | PASS |
| | 802.11g | 1channel | Plot C1 | 13channel | Plot D1 | PASS |
| | 802.11n20 | 1channel | Plot E1 | 13channel | Plot F1 | PASS |
| | 802.11n40 | 3channel | Plot G1 | 11channel | Plot H1 | PASS |

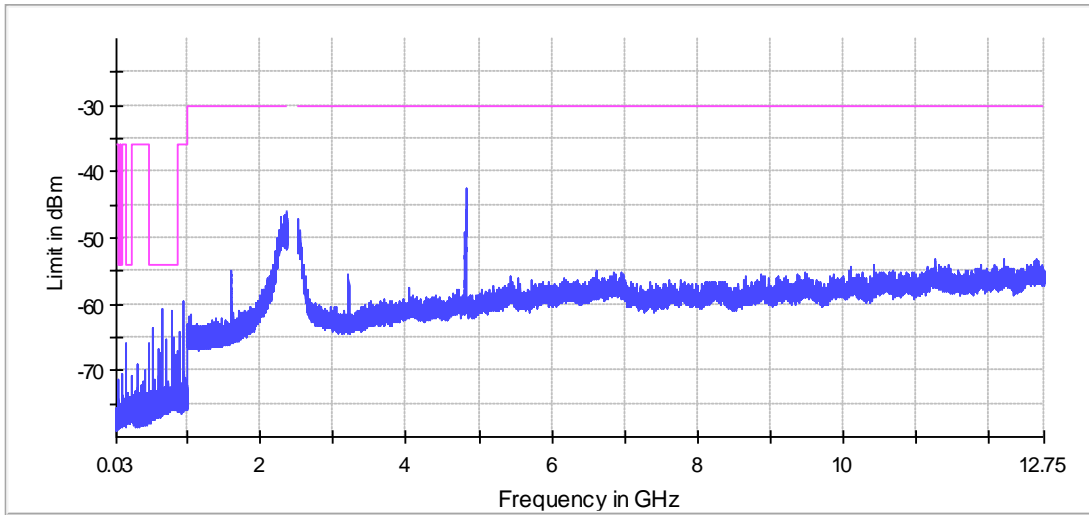

Plot A1

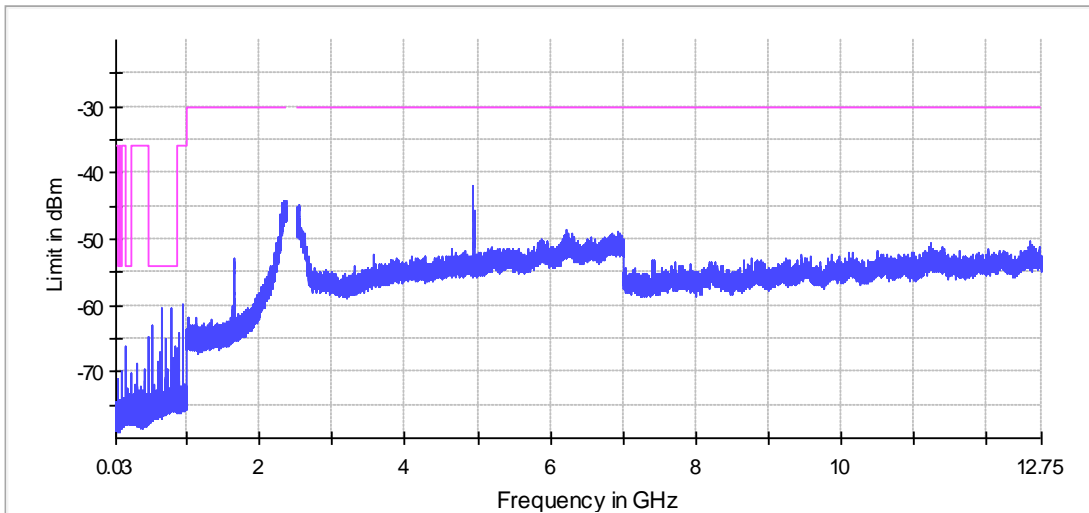

Plot B1



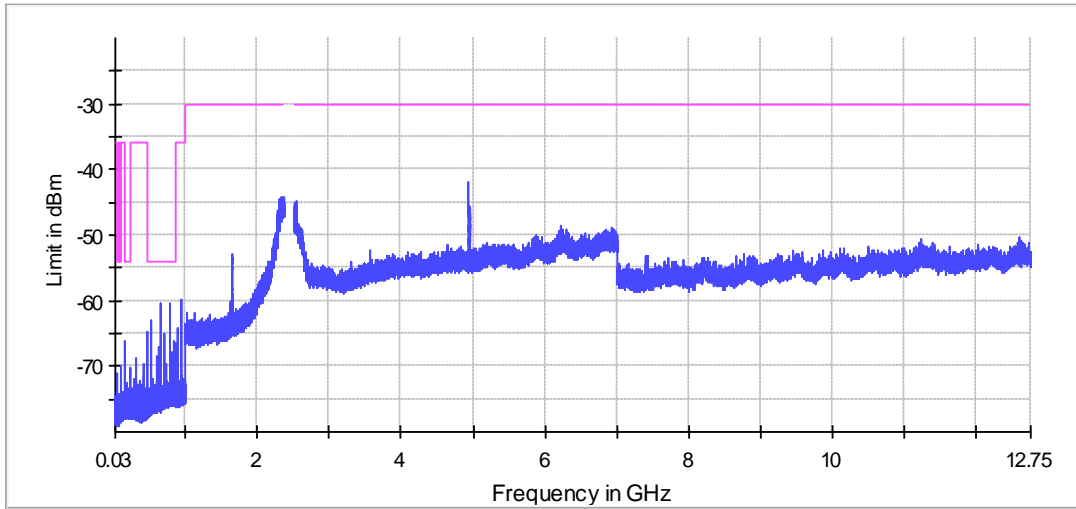

Plot C1

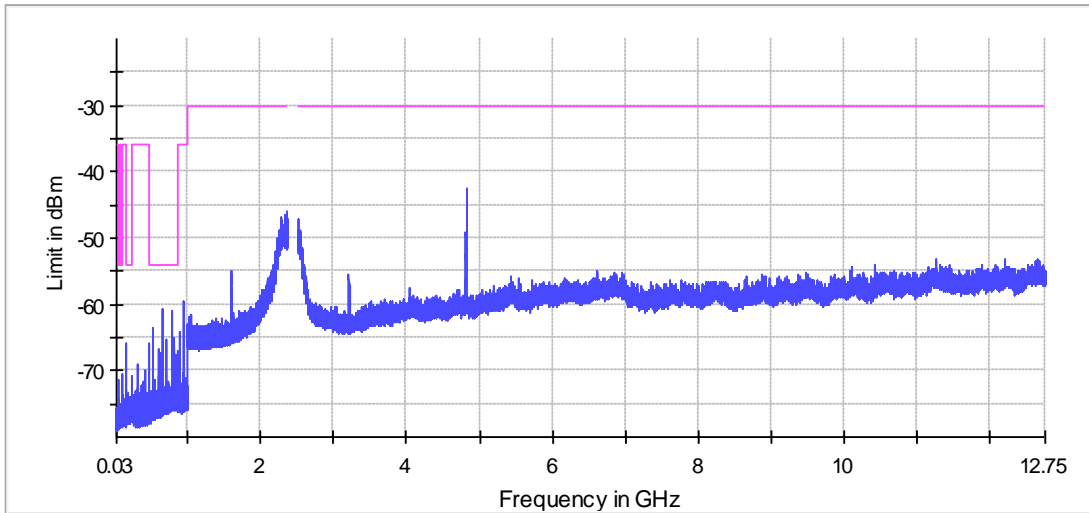

Plot D1

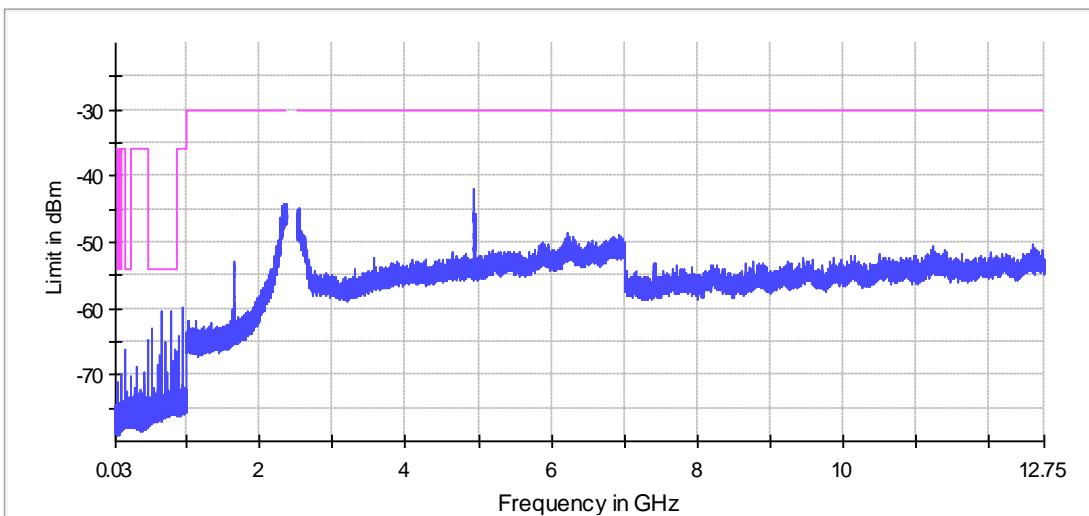

Plot E1



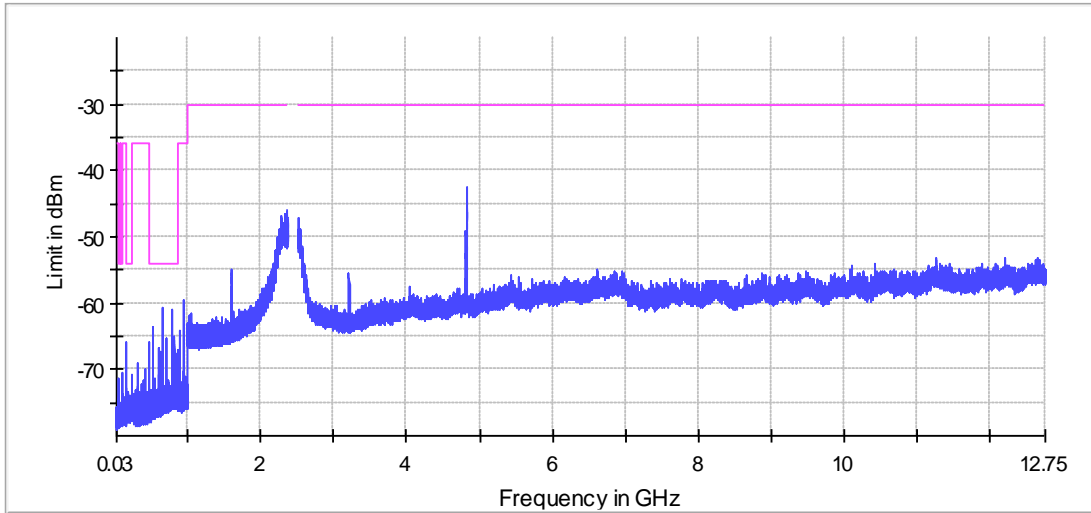

Plot F1

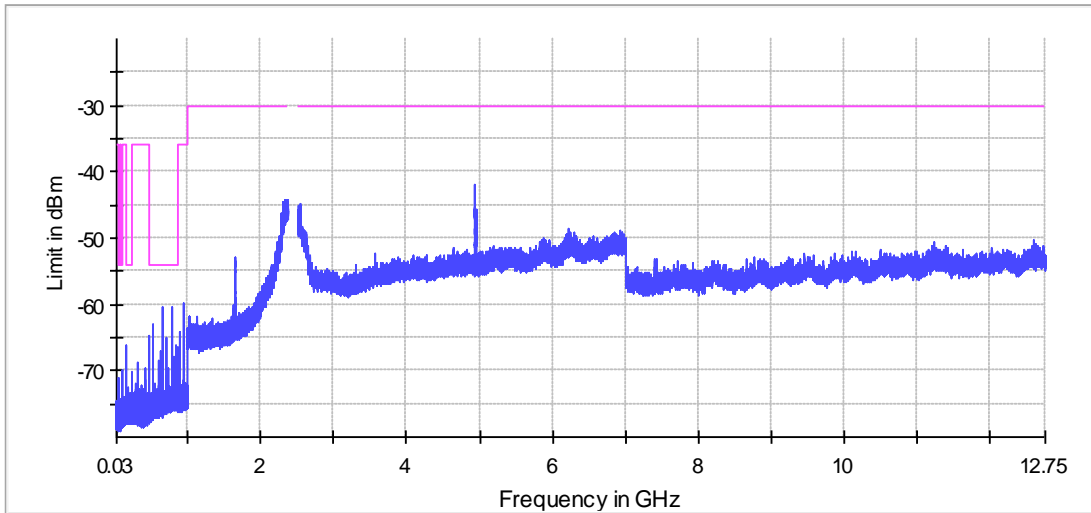

Plot G1

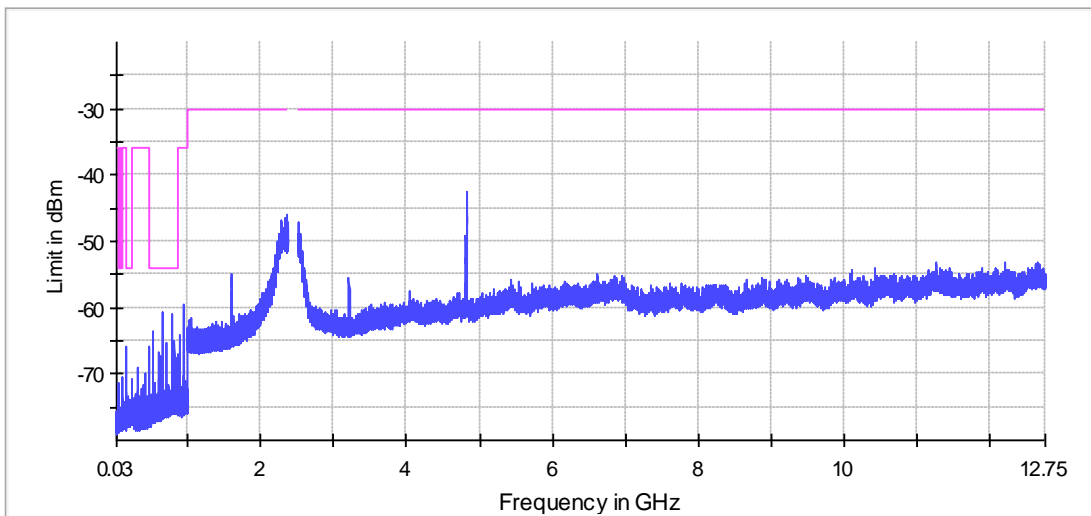

Plot H1



3. Receiver Parameters

3.1 EN 300 328 §4.3.1.10 - Receiver spurious emissions

Receiver spurious emissions are emissions at any frequency when the equipment is in receive mode.

3.1.1 Test Limit

| Frequency range | Maximum power, e.r.p. (\leq 1 GHz) e.i.r.p. ($>$ 1 GHz) (dBm) | Bandwidth |
|------------------|--|-----------|
| 30MHz to 1GHz | -57 | 100KHz |
| 1GHz to 12.75GHz | -47 | 1MHz |

3.1.2 Test Configuration

Please refer to 2.2.2

3.1.3 Test procedure

Please refer to ETSI EN 300 328 (V1.8.1) Sub-clause 5.3.11 for the measurement method.

The conducted measurement method was used in this report.

In case of conducted measurements, the radio equipment shall be connected to the measuring equipment via a suitable attenuator. The spectrum in the spurious domain (see figures 1 or 3) shall be searched for emissions that exceed the limit values given in tables 2 or 5 or that come to within 6 dB below these limits. Each occurrence shall be recorded.

Testing shall be performed when the equipment is in a receive-only mode.

For systems using wide band modulations other than FHSS, the measurement shall be performed at the lowest and the highest channel on which the equipment can operate. These frequencies shall be recorded.

The measurement procedure shall be as follows.

Pre-scan

The test procedure below shall be used to identify potential unwanted emissions of the UUT.

Step 1:

The sensitivity of the spectrum analyser should be such that the noise floor is at least 12 dB below the limits given in tables 2 or 5.

Step 2:

The emissions over the range 30 MHz to 1 000 MHz shall be identified.

Spectrum analyser settings:

- Resolution bandwidth: 100 kHz
- Video bandwidth: 300 kHz
- Detector mode: Peak
- Trace Mode: Max Hold
- Sweep Points: \geq 9 970
- Sweep time: Auto

Allow the trace to stabilize. Any emissions identified during the sweeps above and that fall within the 6 dB range below the applicable limit or above, shall be individually measured using the procedure in clause 5.3.11.2.1.2 and compared to the limits given in tables 2 or 5.

Step 3:

The emissions over the range 1 GHz to 12,75 GHz shall be identified.

Spectrum analyser settings:

- Resolution bandwidth: 1 MHz
- Video bandwidth: 3 MHz
- Detector mode: Peak
- Trace Mode: Max Hold
- Sweep Points: $\geq 11\ 750$
- Sweep time: Auto

Allow the trace to stabilize. Any emissions identified during the sweeps above that fall within the 6 dB range below the applicable limit or above, shall be individually measured using the procedure in clause 5.3.11.2.1.2 and compared to the limits given in tables 2 or 5.

Frequency Hopping equipment may generate a block (or several blocks) of spurious emissions anywhere within the spurious domain. If this is the case, only the highest peak of each block of emissions shall be measured using the procedure in clause 5.3.11.2.1.2.

Step 4:

• In case of conducted measurements on smart antenna systems (equipment with multiple receive chains), the steps 2 and 3 need to be repeated for each of the active receive chains (Ach). The limits used to identify emissions during this pre-scan need to be reduced with $10 \times \log_{10}(\text{Ach})$ (number of active receive chains).

Measurement of the emissions identified during the pre-scan

The steps below shall be used to accurately measure the individual unwanted emissions identified during the pre-scan measurements above.

Step 1:

The level of the emissions shall be measured using the following spectrum analyser settings:

- Centre Frequency: Frequency of emission identified during the pre-scan
- Resolution Bandwidth: 100 kHz (< 1 GHz) / 1 MHz (> 1 GHz)
- Video Bandwidth: 300 kHz (< 1 GHz) / 3 MHz (> 1 GHz)
- Frequency Span: Wide enough to capture each individual emission identified during the

pre-scan

- Sweep mode: Continuous
- Sweep time: Auto
- Trigger: Free run
- Detector: RMS
- Trace Mode: Max Hold

Step 2:

In case of conducted measurements on smart antenna systems (equipment with multiple receive chains), the step 1 needs to be repeated for each of the active receive chains (Ach).

The trace data for each receive chain has to be recorded.

Sum the power in each of the traces for each individual frequency bin.

Step 3:

Use the marker function to find the highest peak within the measurement trace and record its value and its frequency.

Step 4:

The measured values shall be compared to the limits defined in tables 2 and 5.

3.1.4 Test Results

| Mode No. | Mode | Low Channel | Refer to plot | High Channel | Refer to plot | Result |
|---------------|-----------|-------------|---------------|--------------|---------------|--------|
| GWF-3M08-3.3V | 802.11b | 1channel | Plot A | 13channel | Plot B | PASS |
| | 802.11g | 1channel | Plot C | 13channel | Plot D | PASS |
| | 802.11n20 | 1channel | Plot E | 13channel | Plot F | PASS |
| | 802.11n40 | 3channel | Plot G | 11channel | Plot H | PASS |

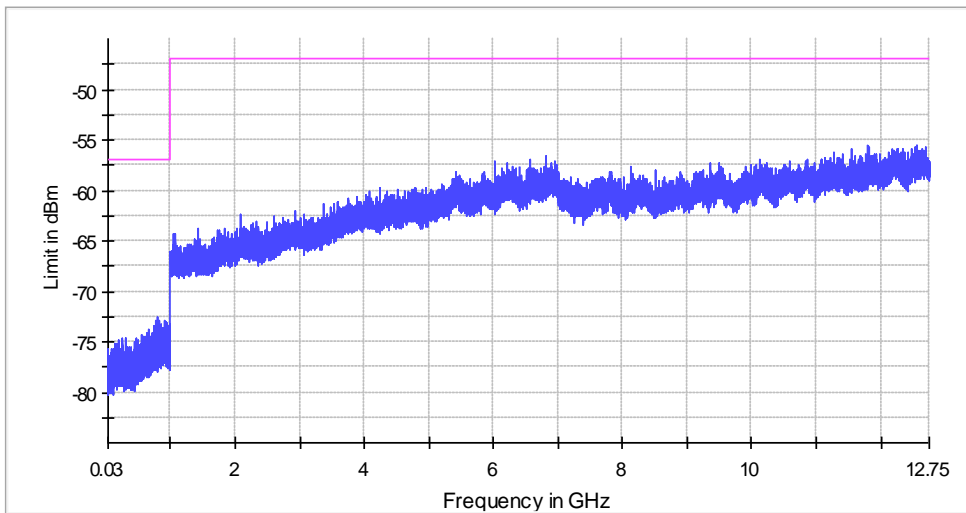

Plot A

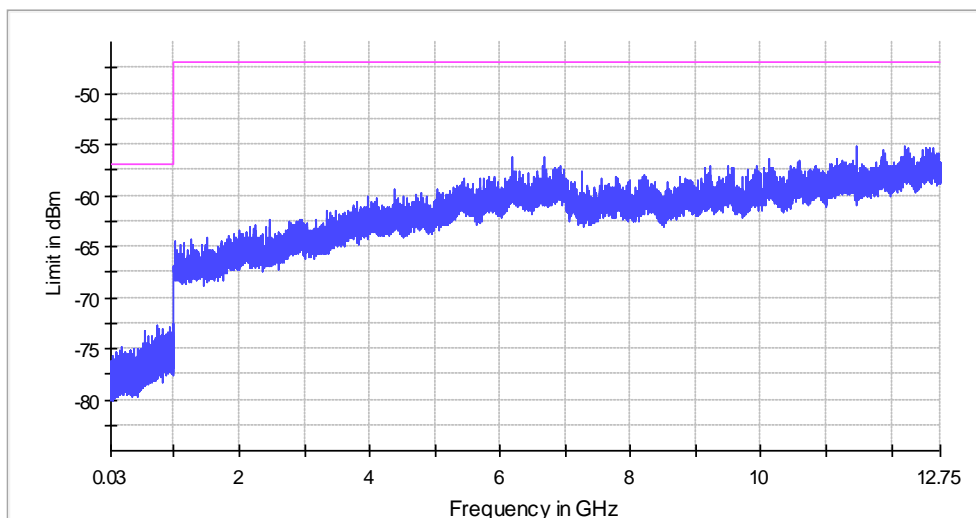

Plot B

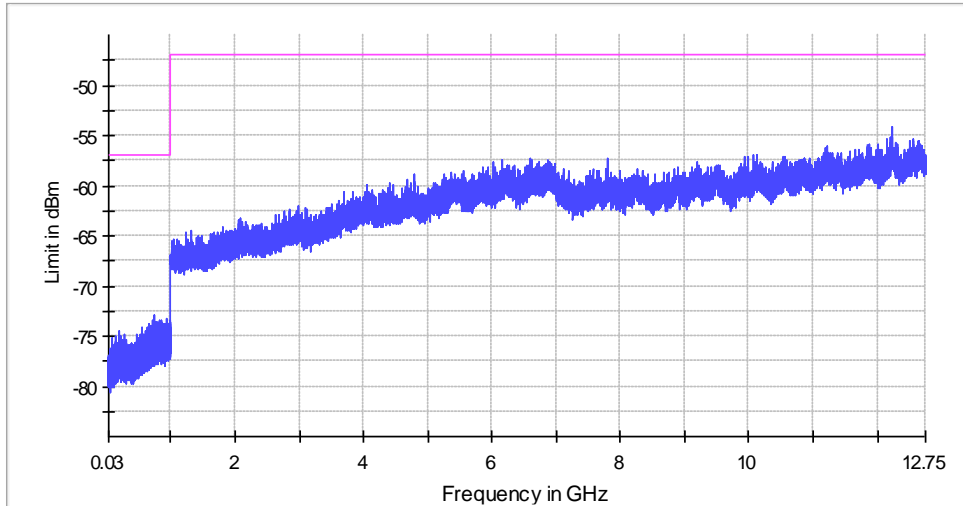

Plot C

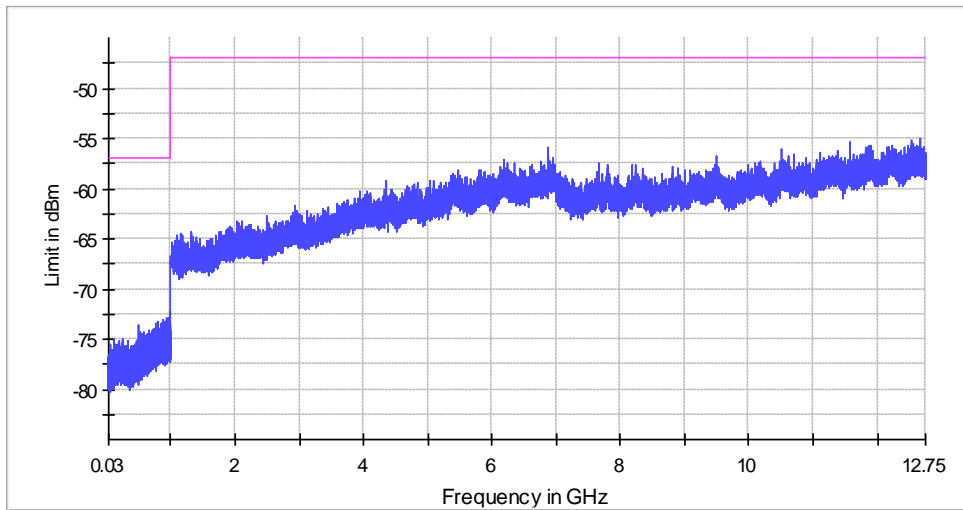

Plot D

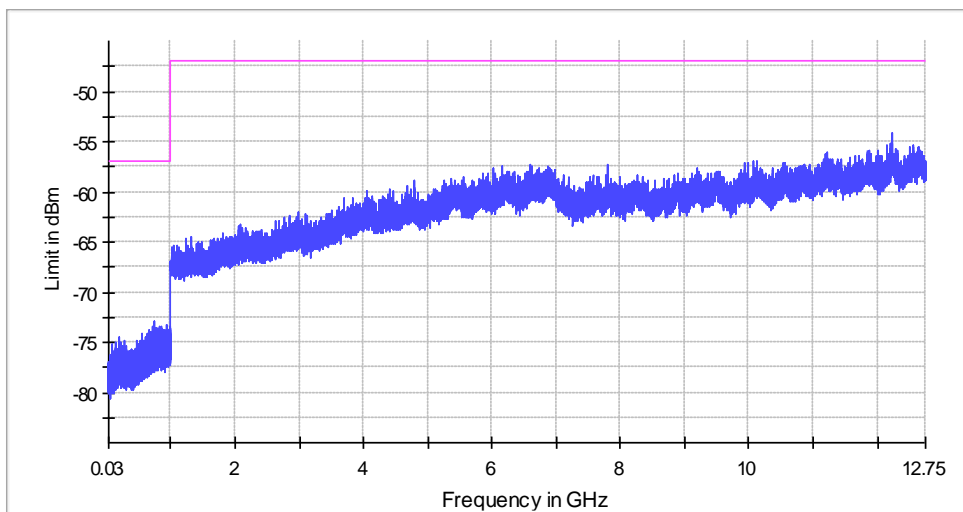

Plot E



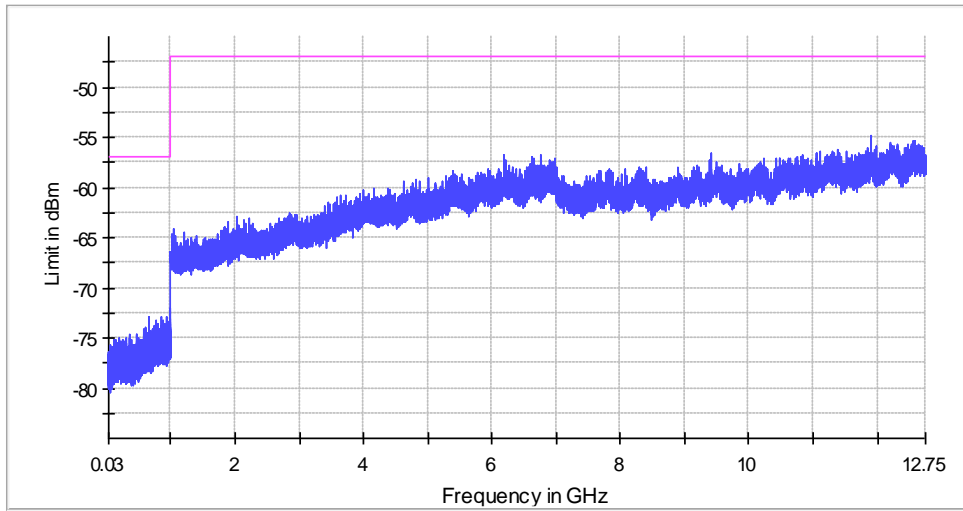

Plot F

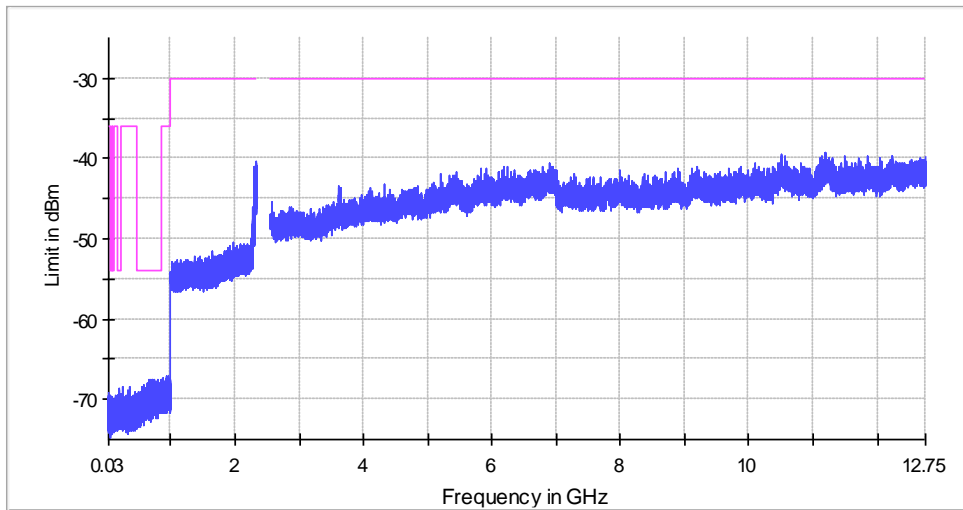

Plot G

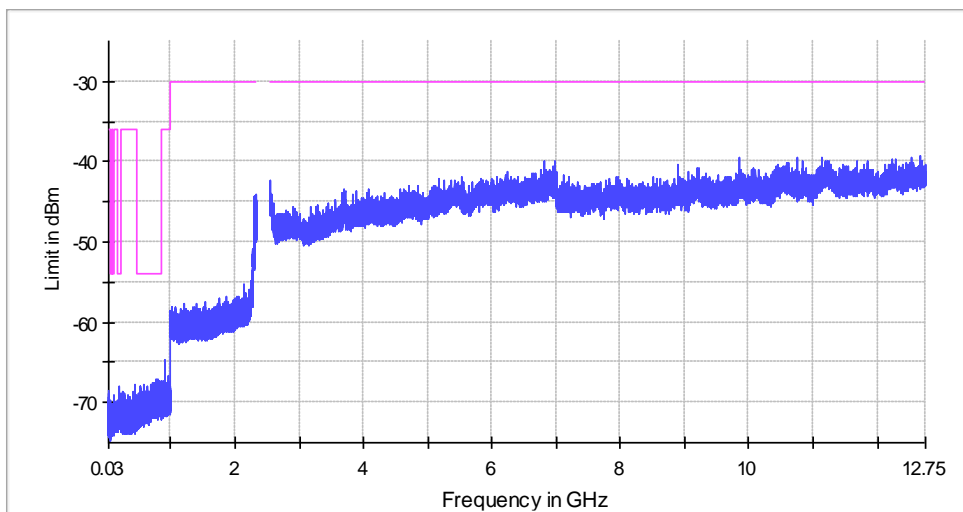

Plot H



| Mode No. | Mode | Low Channel | Refer to plot | High Channel | Refer to plot | Result |
|-------------|-----------|-------------|---------------|--------------|---------------|--------|
| GWF-3M08-5V | 802.11b | 1channel | Plot A1 | 13channel | Plot B1 | PASS |
| | 802.11g | 1channel | Plot C1 | 13channel | Plot D1 | PASS |
| | 802.11n20 | 1channel | Plot E1 | 13channel | Plot F1 | PASS |
| | 802.11n40 | 3channel | Plot G1 | 11channel | Plot H1 | PASS |

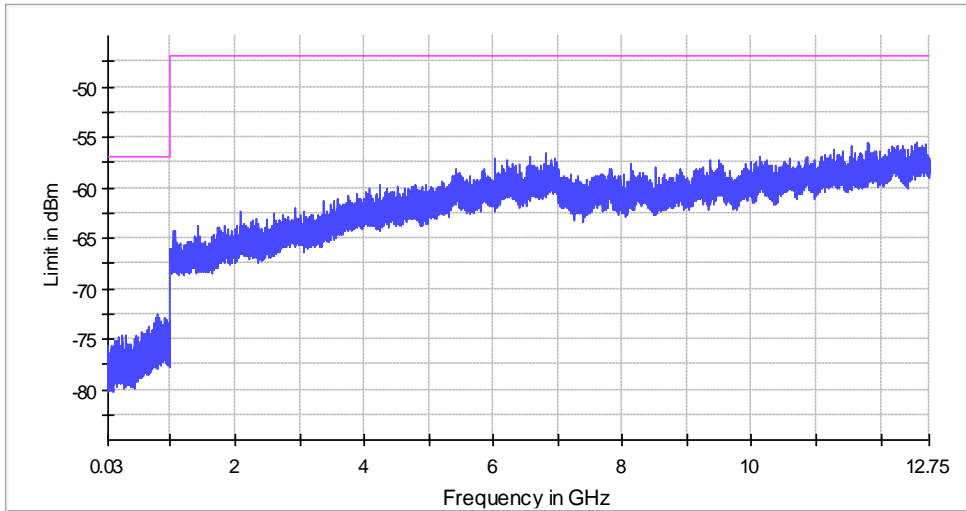

Plot A1

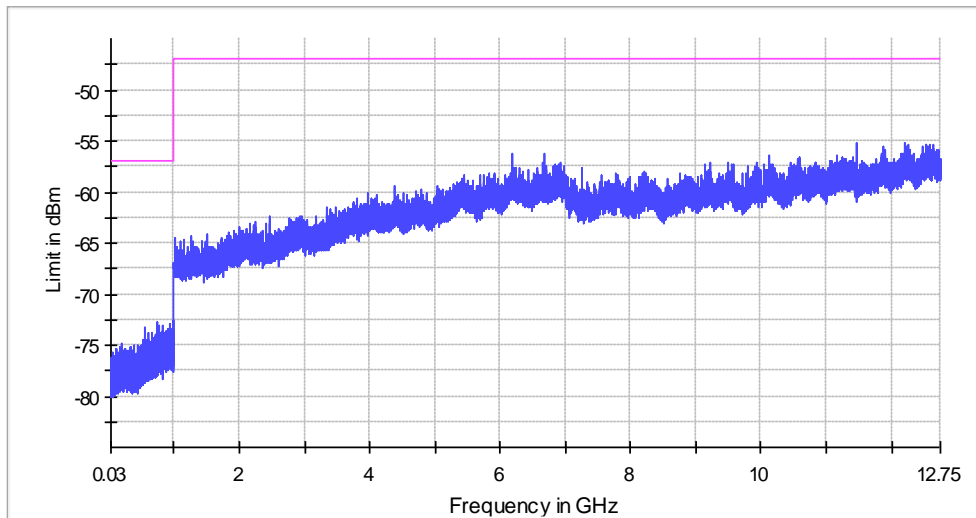

Plot B1



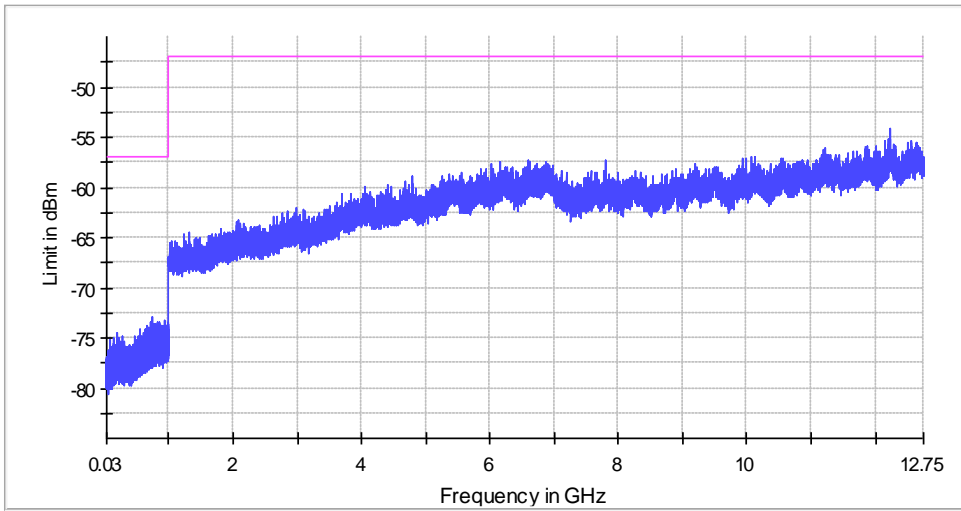

Plot C1

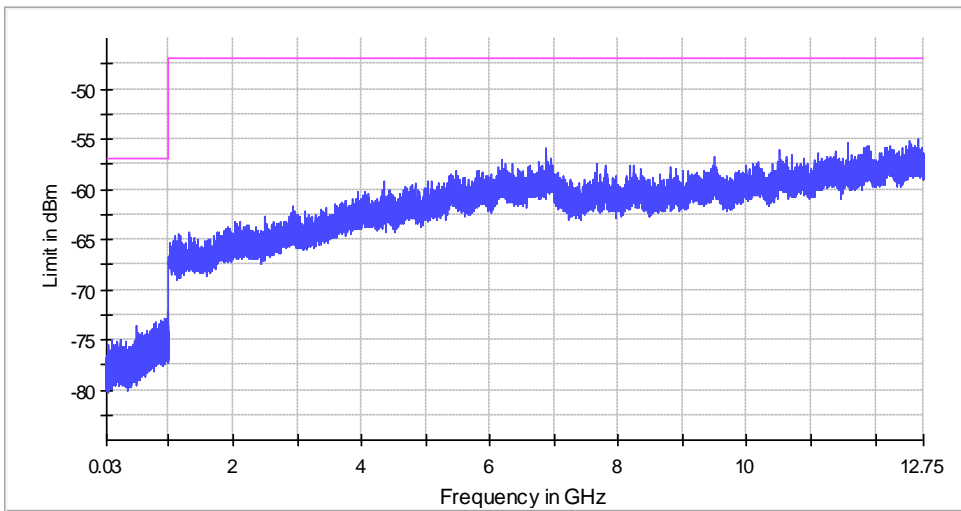

Plot D1

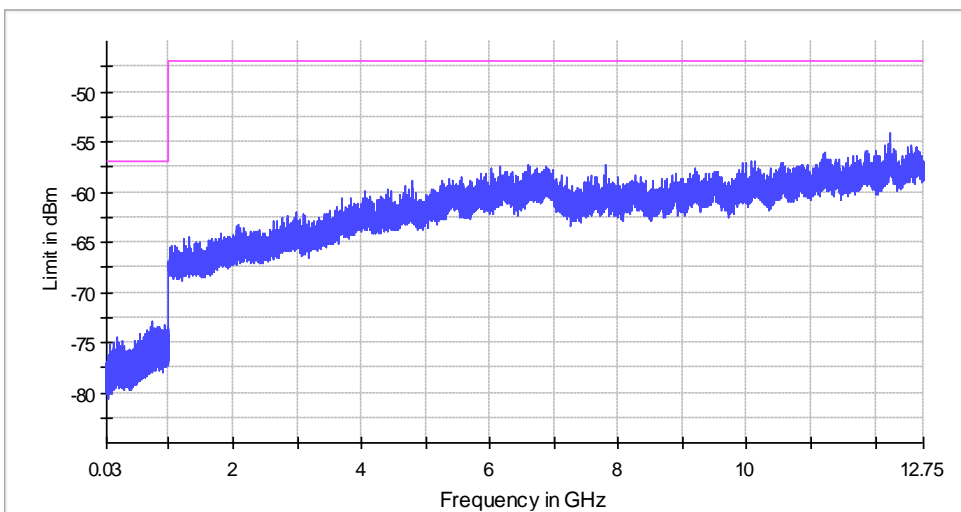

Plot E1



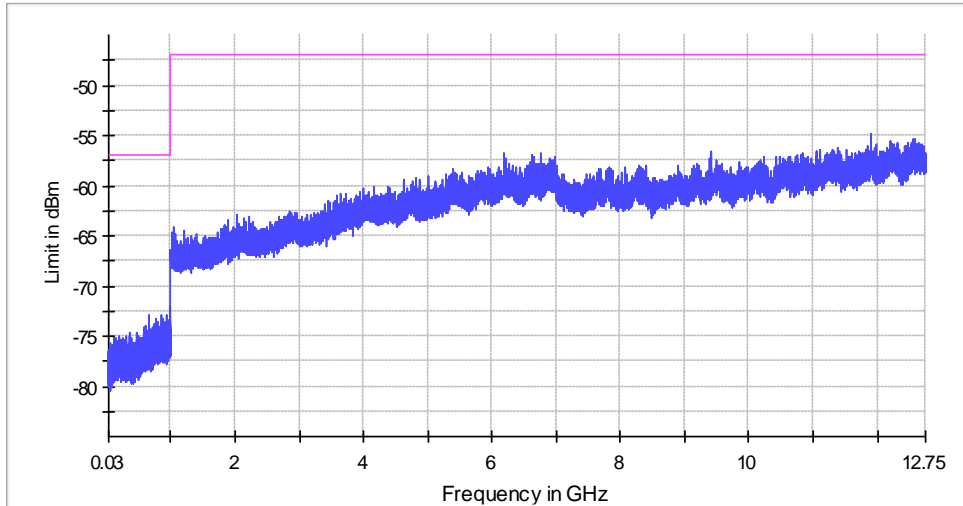

Plot F1

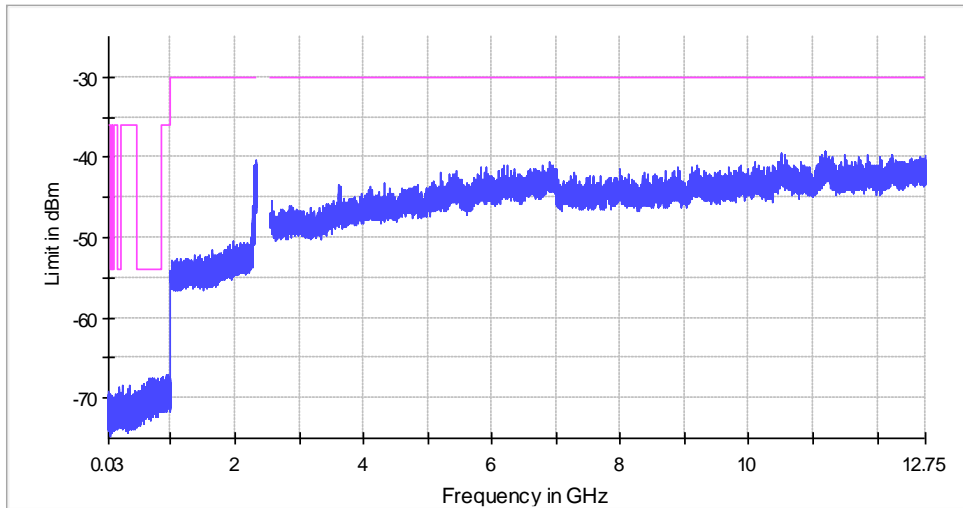

Plot G1

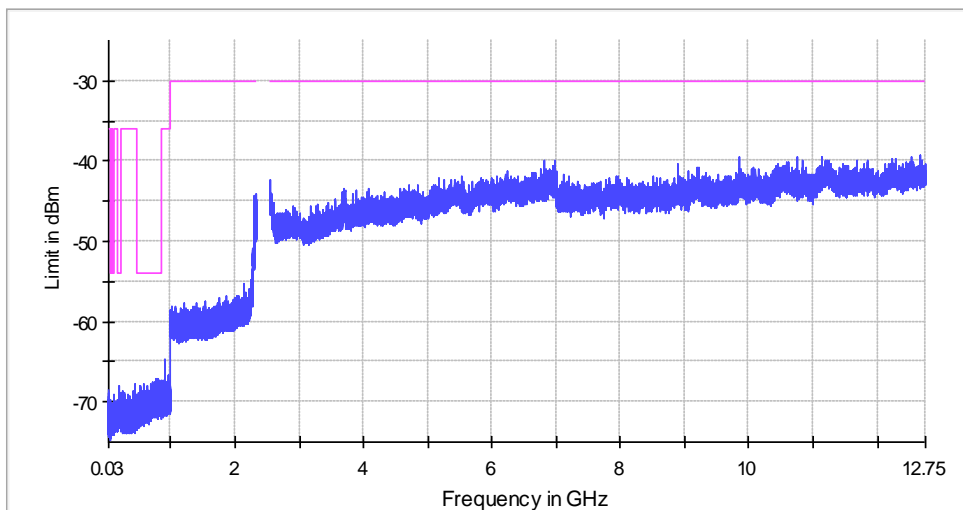

Plot H1



Annex A Accreditation Certificate**China National Accreditation Service for Conformity Assessment****LABORATORY ACCREDITATION CERTIFICATE****(Registration No. CNAS L1659)****CCIC Southern Electronic Product Testing (Shenzhen) Co., Ltd.**Building 28/29, Shigudong, Xili Industrial Area, Xili Street,Nanshan District, Shenzhen, Guangdong, China

is accredited to ISO/IEC 17025:2005 General Requirements for the Competence of Testing and Calibration Laboratories(CNAS-CL01 Accreditation Criteria for the Competence of Testing and Calibration Laboratories) for the competence of testing and calibration.

The scope of accreditation is detailed in the attached appendices bearing the same registration number as above. The appendices form an integral part of this certificate.

Date of Issue: 2012-09-29

Date of Expiry: 2015-09-28

Date of Initial Accreditation: 1999-08-03

Date of Update: 2012-09-29

Signed on behalf of China National Accreditation Service
for Conformity Assessment

China National Accreditation Service for Conformity Assessment (CNAS) is authorized by Certification and Accreditation Administration of the People's Republic of China (CNCA) to operate the national accreditation scheme for conformity assessment. CNAS is the signatory to International Laboratory Accreditation Cooperation Multilateral Recognition Arrangement (ILAC MRA) and Asia Pacific Laboratory Accreditation Cooperation Multilateral Recognition Arrangement (APLAC MRA).

No.CNAS AL 2

0005210

Annex B Information as required by EN 300 328 V1.8.1 clause 5.3.1

In accordance with EN 300 328, clause 5.3.1, the following information is provided by the supplier.

Mode No.: GWF-3M08-3.3V

1. The type of modulation used by the equipment: other forms of modulation

2. Adaptive/non-adaptive equipment

Adaptive Equipment without the possibility to switch to a non-adaptive mode.

3. In case of adaptive equipment

The equipment has implemented an LBT based DAA mechanism.

The equipment is Load Based equipment.

The CCA time implemented by the equipment: 20 μ s

The value q as referred to in clause 4.3.2.5.2.2.2: 32

4. The worst case operational mode for each of the following tests:

a. RF Output Power: 17.7dBm(802.11b mode is the worst mode)

b. Power Spectral Density: 8.5dBm(802.11b mode is the worst mode)

c. Adaptivity: 2.160ms(802.11n HT40 mode is the worst mode)

d. Occupied Channel Bandwidth 1: 18.215MHz

Occupied Channel Bandwidth 2: 36.392MHz

d. Transmitter unwanted emissions in the OOB domain: -33.84dBm(802.11n40 mode is the worst mode)

e. Transmitter unwanted emissions in the spurious domain: -42.37dBm(802.11b mode is the worst mode)

i. Receiver spurious emissions: -56.46dBm(802.11b mode is the worst mode)

5. Operating mode 1: Single Antenna Equipment

Equipment with only 1 antenna

6. Operating Frequency Range(s) of the equipment:

Operating Frequency Range 1: 2412MHz to 2472MHz

Operating Frequency Range 2: 2422MHz to 2462MHz

7. Occupied Channel Bandwidth(s):

Occupied Channel Bandwidth 1: 20MHz

Occupied Channel Bandwidth 1: 40MHz

8. Type of Equipment: stand-alone

9. The extreme operating conditions that apply to the equipment:

Operating temperature range: -20 $^{\circ}$ C to 55 $^{\circ}$ C

Operating voltage range: 3.15V to 3.45V (DC)

Supply Voltage: State DC voltage 3.3V

10. Integral Antenna

Antenna Gain: 2dBi

11. The equipment type: IEEE802.11 .b/g/n(HT20/HT40)

12. About the UUT

The equipment submitted are representative production models.

If pre-production equipment are submitted, the final production equipment will be identical in all respects with the equipment tested. The equipment submitted is CE marked.

Mode No.: GWF-3M08-5V

1. The type of modulation used by the equipment: other forms of modulation

2. Adaptive/non-adaptive equipment

Adaptive Equipment without the possibility to switch to a non-adaptive mode.

3. In case of adaptive equipment

The equipment has implemented an LBT based DAA mechanism.

The equipment is Load Based equipment.

The CCA time implemented by the equipment: 20 μ s

The value q as referred to in clause 4.3.2.5.2.2.2: 32

4. The worst case operational mode for each of the following tests:

a. RF Output Power: 17.6dBm(802.11b mode is the worst mode)

b. Power Spectral Density: 8.4dBm(802.11b mode is the worst mode)

c. Adaptivity: 2.122ms(802.11n HT40 mode is the worst mode)

d. Occupied Channel Bandwidth 1: 18.238MHz

Occupied Channel Bandwidth 2: 36.410MHz

d. Transmitter unwanted emissions in the OOB domain: -33.34dBm(802.11n40 mode is the worst mode)

e. Transmitter unwanted emissions in the spurious domain: -42.61dBm(802.11b mode is the worst mode)

i. Receiver spurious emissions: -56.33dBm(802.11b mode is the worst mode)

5. Operating mode 1: Single Antenna Equipment

Equipment with only 1 antenna

6. Operating Frequency Range(s) of the equipment:

Operating Frequency Range 1: 2412MHz to 2472MHz

Operating Frequency Range 2: 2422MHz to 2462MHz

7. Occupied Channel Bandwidth(s):

Occupied Channel Bandwidth 1: 20MHz

Occupied Channel Bandwidth 1: 40MHz

8. Type of Equipment: stand-alone

9. The extreme operating conditions that apply to the equipment:

Operating temperature range: -20 $^{\circ}$ C to 55 $^{\circ}$ C

Operating voltage range: 4.75V to 5.25V (DC)

Supply Voltage: State DC voltage 5V

10. Integral Antenna

Antenna Gain: 2dBi

11. The equipment type: IEEE802.11 .b/g/n(HT20/HT40)

12. About the UUT

The equipment submitted are representative production models.

If pre-production equipment are submitted, the final production equipment will be identical in all respects with the equipment tested. The equipment submitted is CE marked.



Annex C Photos of the EUT

Mode No.: GWF-3M08-3.3V

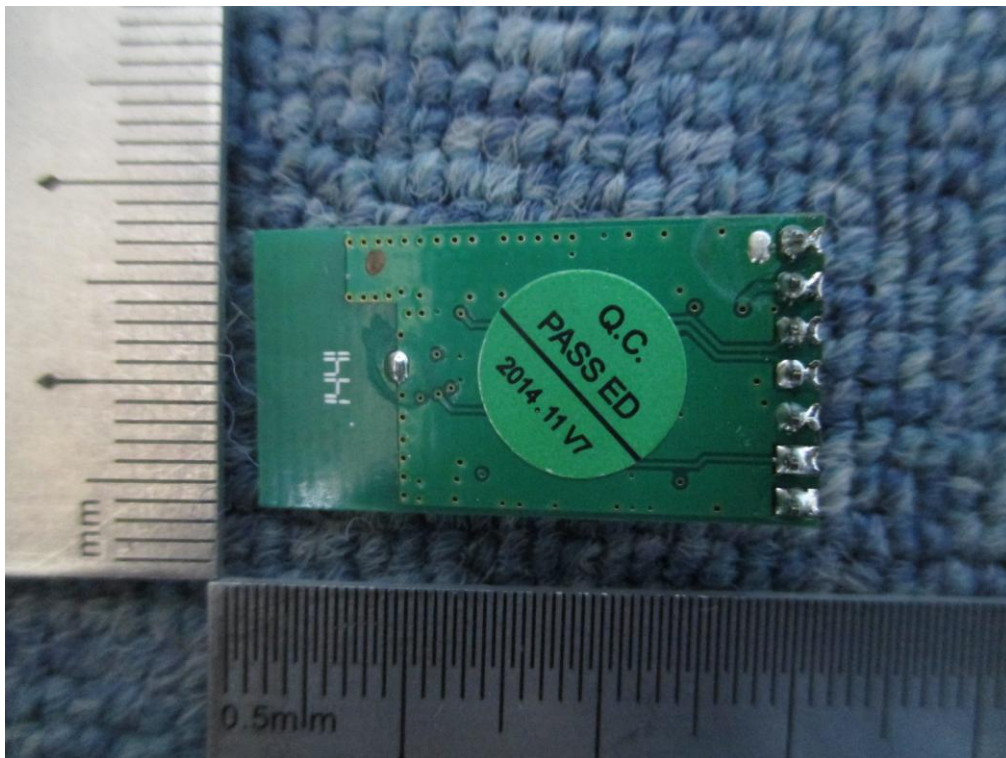
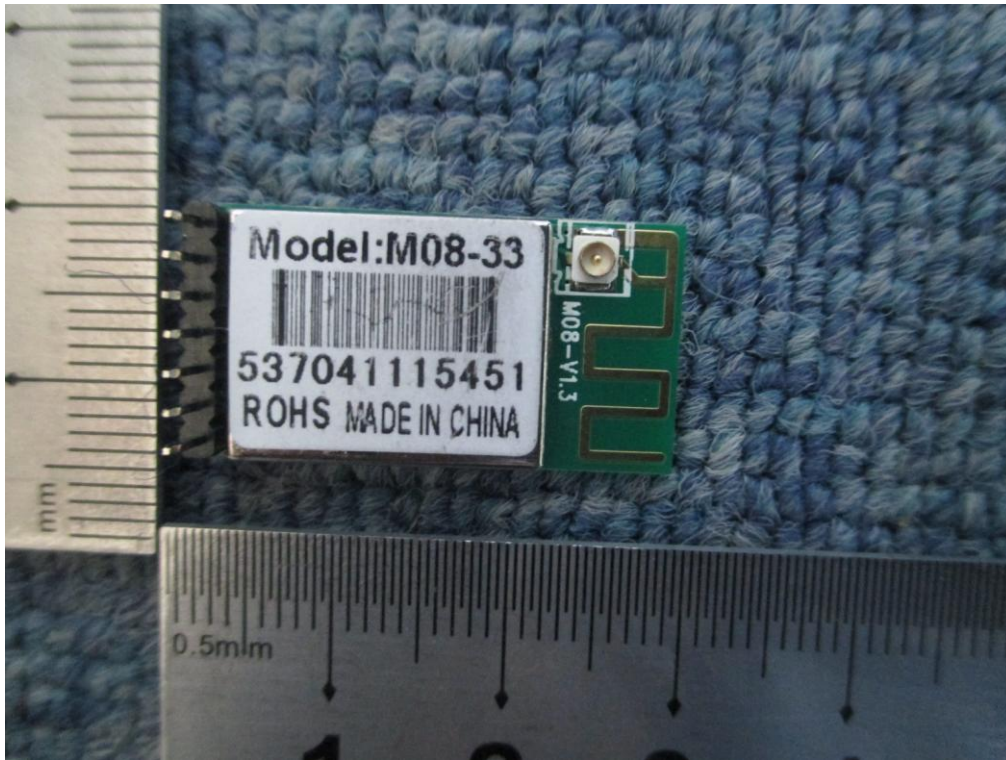

Mode No.: GWF-3M08-5V

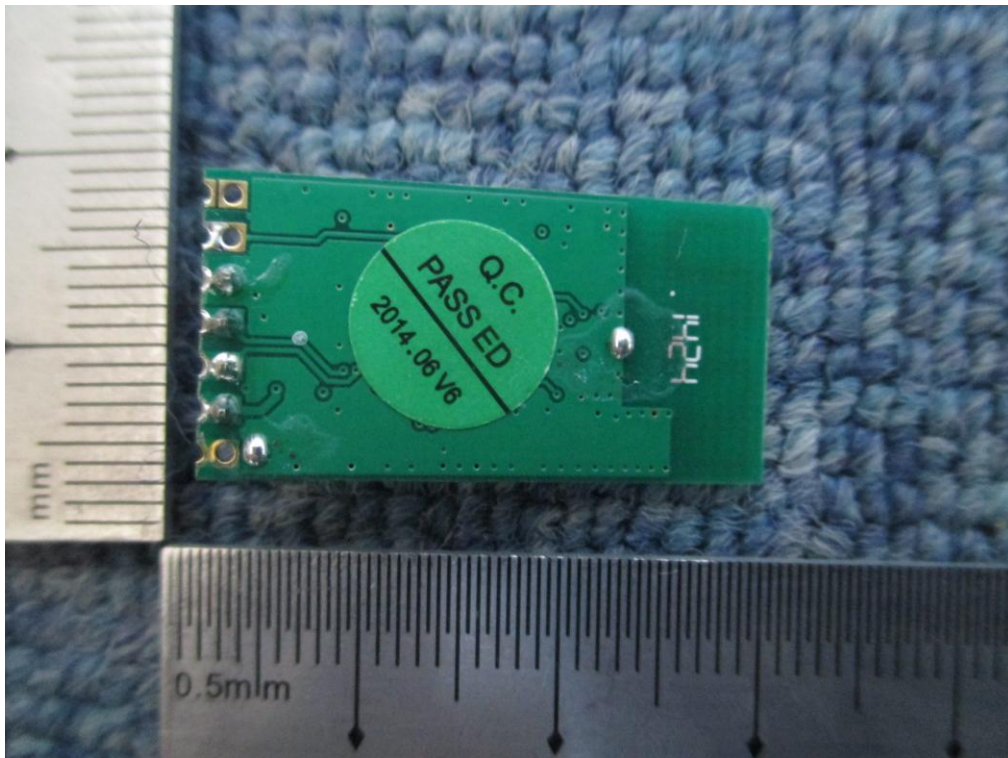

Annex D Photos of Test Setup

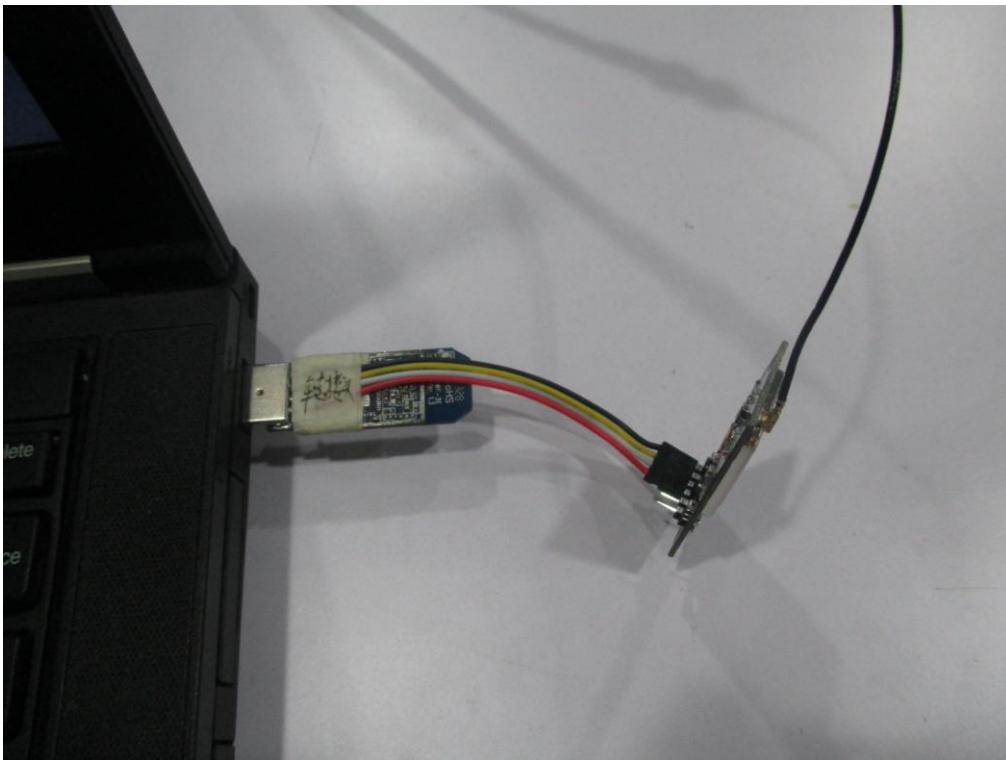

**** END OF REPORT ****